



# LB Series - LB / LBV / LBK / LBC Submersible Effluent, Vortex, Non-Clog & Cutter Pump

*The most efficient, versatile and cost-effective products you'll ever use.*



**A** very complete series of submersible pump have been developed to meet your various requirements. In general, you are suggested to use LB series as drainage pump for liquid effluent pumping applications, LBV series as vortex pump for raw sewage applications and LBC series as cutter pump to chop the solids in wastewater. The pumps are constructed of following parts in common:

## **Pump section**

- completely sealed water resistance cable entry,
- cast iron outer casing for superior heat dissipation,
- quality stainless steel 410 heat treated shaft,
- double mechanical seals (Carbon-Ceramic + Carbon-Ceramic) in oil chamber for exceptional durability,
- dynamically balanced cast iron impeller,
- lubricated-for-life and maintenance free bearings to support shaft,
- and standard 6 meters (20ft) power cord (or longer upon request).

## **Motor section**

- Oil-free motor with built-in thermal protector for single phase motor up to 0.75kw (1hp) or higher upon request.
- Asynchronous 1 & 3 phase, 2 pole, 50Hz/2850rpm or 60Hz/3450rpm.
- Max. liquid temperature: 40°C (104°F)
- Max. submerged depth: 8 meters ( 26ft )
- Water level control: external single ball float optional (brand to be decided by the manufacturer)
- 2" & 3" guide rail fittings are available upon request.

# LB Series

**LB-25 / 40 / 75 / 215 / 315**

for various drainage and effluent applications.

**Discharge: 25mm ( 1.5" ), 50mm ( 2" ), and 80mm ( 3" )**

**Power Output: 250w (1/3hp) ~ 1.5kw (2hp)**

**Head: up to 22mm (72ft)**

**Flow: up to 650 l/min (175 USgpm)**



## Performance Curve

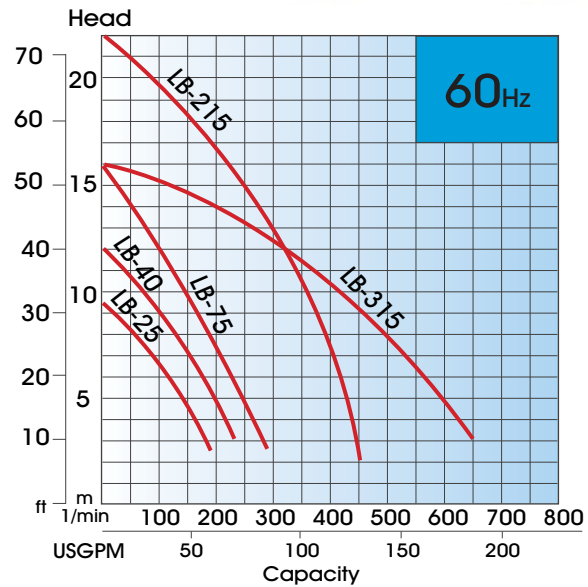
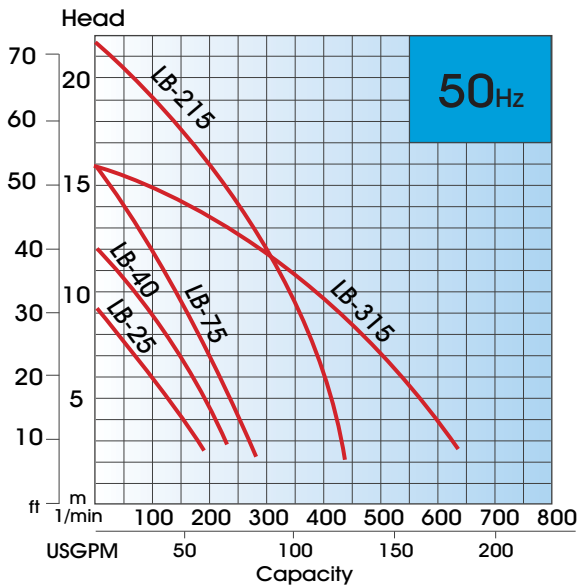

## Technical Specifications

Type	Outlet		Output		Voltage 1P & 3P	Nor.Head		Nor.Capa.		Max.Head		Max.Capa		Solid Pass.		Weight	
	mm	inch	watt.	hp		m	ft	l/min	USgpm	m	ft	l/min	USgpm	mm	inch	kg	1b
LB-25	40	1 1/2	250	1/3	110/220v 220-240v	6	20	120	32	9.5	31	200	53	4	0.16	13.5	29.8
LB-40	50	2	400	1/2		8	26	130	34	12	39	240	63	4	0.16	15	32
LB-75	50	2	750	1	3p: 220/380v 415/440v	10	33	160	42	16	53	280	74	6	0.24	21	46
LB-215	50	2	1500	2		15	49	250	66	22	72	450	119	8	0.32	25	55
LB-315	80	3	1500	2	8	26	500	132	16	53	650	172	8	0.32	25	55	

## Dimensions & main parts description

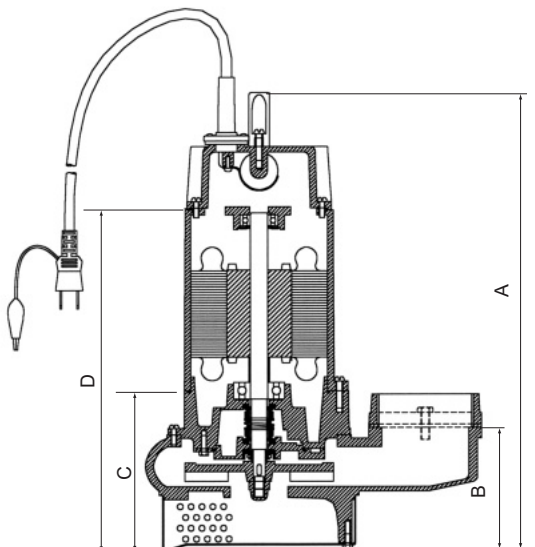

- Epoxy sealed watertight cable gland and waterproof joints.
- Cast iron FC 200 top cover & Cast iron FC200 motor casing
- Stainless steel 410 heat treated shaft
- Double mechanical seal ( CE / CA + CE / CA )
- Cast iron FC200 bearing bracket & Cast iron FC 200 seal bracket
- Cast iron FC200 pump casing
- Cast iron multi-van impeller
- Stainless steel 304 strainer, screws & washers.

Type	A		B		C		D	
LB-25/40	340mm	13.4in	82mm	3.2in	125mm	4.9in	250mm	9.8in
LB-75	380mm	15.0in	115mm	4.5in	140mm	5.5in	270mm	10.6in
LB-215/315	430mm	16.9in	105mm	4.1in	130mm	5.1in	330mm	13.0in

# LBV Series

**LBV-25 / 40 / 75 / 215 / 315**

for residential raw sewage or liquid effluent pumping applications

**Discharge: 25mm ( 1.5" ), 50mm ( 2" ), and 80mm ( 3" )**

**Power Output: 250w (1/3hp) ~ 1.5kw (2hp)**

**Head: up to 18m (60ft)**

**Flow: up to 600 l/min (160 USgpm)**



## Performance Curve

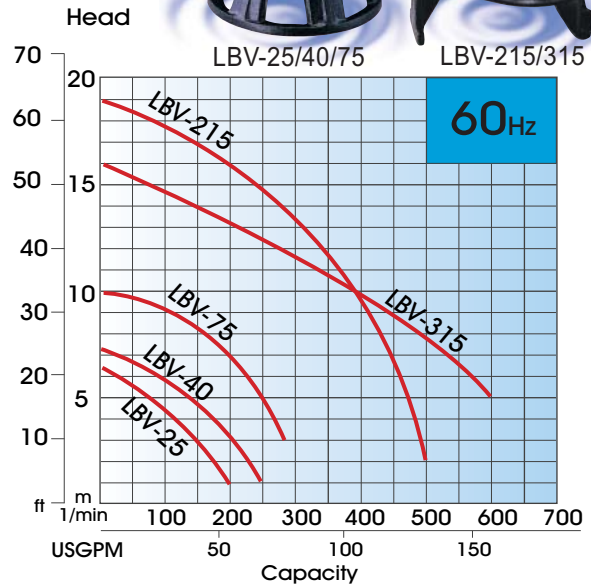
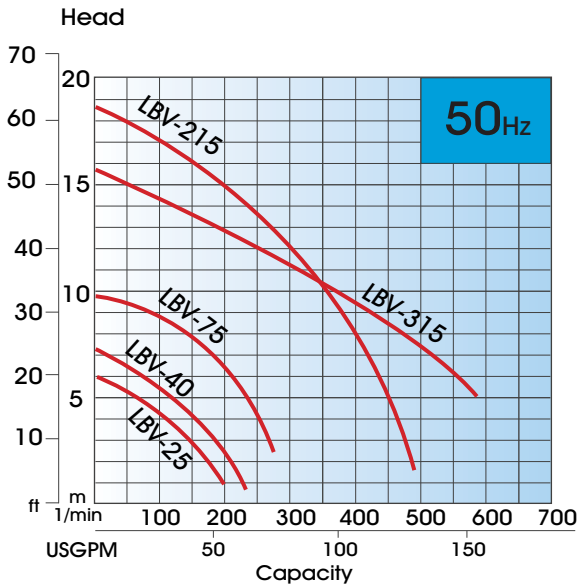

## Technical Specifications

Type	Outlet		Output		Voltage 3 phase	Nor.Head		Nor.Capa.		Max.Head		Max.Capa.		Solid Pass.		Weight	
	mm	inch	watt.	hp		m	ft	l/min	USgpm	m	ft	l/min	USgpm	mm	inch	kg	lb
LBV-25	40	1 1/2	250	1/3	1p:110v/	4.5	15	100	26	6.5	21	200	53	14	0.6	15	32
LBV-40	50	2	400	1/2	220v-240v	5.5	18	100	26	8	26.2	240	63	14	0.6	16	34
LBV-75	50	2	750	1	3p:	8	26	200	53	14	46	300	79	28	1.1	21	46
LBV-215	50	2	1500	2	220/380v	10	33	400	106	18	59	600	159	32	1.3	25	55
LBV-315	80	3	1500	2	415/440v	10	33	400	106	16	53	600	159	32	1.3	25	55

## Dimensions & main parts description

LBV- 25 / 40 / 75

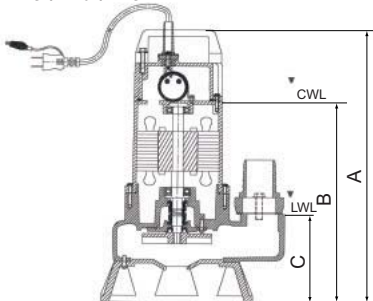

LBV- 215 / 315

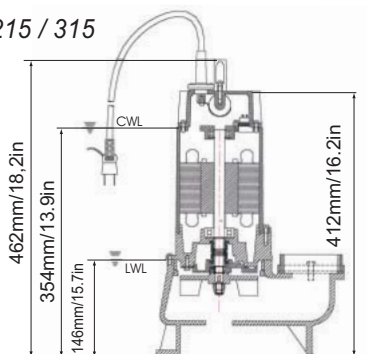

*Epoxy sealed watertight cable gland and waterproof joints.*

*Cast iron FC 200 top cover*

*Cast iron FC200 motor casing*

*Stainless steel 410 heat treated shaft*

*Double mechanical seal ( CE / CA + CE / CA )*

*Cast iron FC200 bearing bracket*

*Cast iron FC 200 seal bracket*

*Cast iron FC200 pump casing*

*Non-clog vortex-designed Cast iron FC200*

*impeller for dealing soft or fibrous particles*

*without clogging*

*Stainless steel 304 screw & washers.*

Type	A		B		C	
LBV-25/40	363mm	14.3in	254mm	10.0in	104mm	4.1in
LBV-75	403mm	15.9in	294mm	11.6in	132mm	5.2in

# LBK & LBC Series

Sewage non-clog pump - LBK-75 / 215 / 315  
 Sewage cutter pump - LBC-75 / 215 / 315

for residential raw sewage and various waste water treatment.

- Discharge: 50mm ( 2" ) or 80mm ( 3" )
- Power Output: 750w (1hp) ~1.5kw (2ph)
- Head: up to 18m (60ft)
- Flow: up to 700l/min (185 USgpm)



## Performance Curve

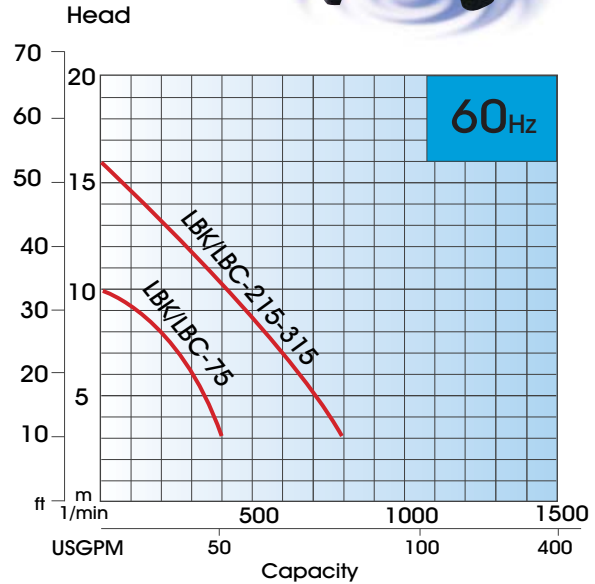
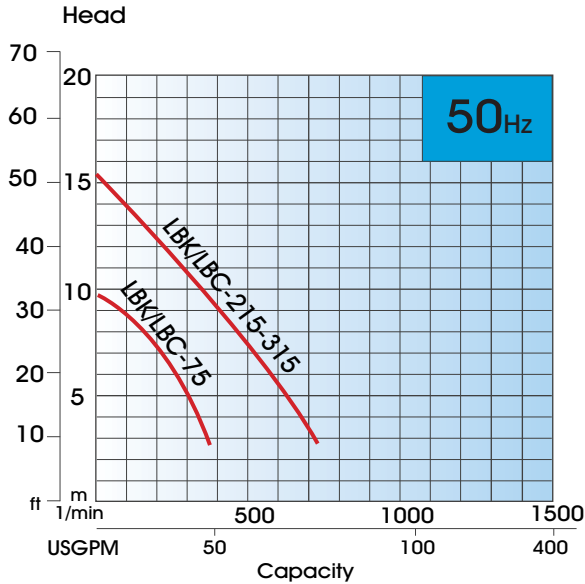

## Technical Specifications

Type	Outlet		Output		Voltage 1p & 3p	Nor.Head		Nor.Capa.		Max.Head		Max.Capa		Solid Pass.		Weight	
	mm	inch	watt.	hp		m	ft	l/min	USgpm	m	ft	l/min	USgpm	mm	inch	kg	lb
LBK-75	50	2	750	1	110/220v 220-240v	8	26	200	53	10	33	400	106	45	1.8	20.5	45
LBK-215	50	2	1500	2		8	26	500	132	18	59	700	185	45	1.8	25	55
LBK-315	80	3	1500	2		8	26	500	132	16	53	700	185	45	1.8	25	55
LBC-75	50	2	750	1	3p: 220/380v 415/440v	8	26	200	53	10	33	400	106	45	1.8	20.5	45
LBC-215	50	2	1500	2		8	26	500	132	18	59	700	185	45	1.8	25	55
LBC-315	80	3	1500	2		8	26	500	132	16	53	700	185	45	1.8	25	55

## Dimensions & main parts description

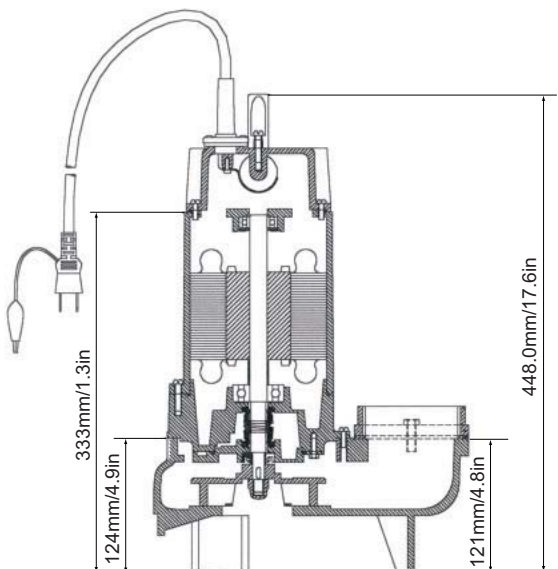

Epoxy sealed watertight cable gland and waterproof joints.

Cast iron FC 200 top cover

Cast iron FC200 motor casing

Stainless steel 410 heat treated shaft

Double mechanical seals ( CE / CA + CE / CA )

Cast iron FC200 pump casing

Impeller:

**LBK Series-**

Unique two-blade non-clog impeller prevents Internal clogging by solids in the pumping liquid.

**LBC Series-**

Tungsten carbide steel tips incorporated with unique chopper plate to cut fibrous materials.