

**Ideal for removal of residual water down to 1mm - for professional use**



Original residue dewatering pump capable of pumping down to floor level. Even the smallest puddle can be pumped dry.

Ideal for complete drainage of flat surfaces where a sump is not available: rooftops, parking lots, garages, roadways, pools,.....

### Features:

- Double mechanical seal with lapped SiC rings in oil bath, as used in large heavy-duty pumps
- When placed directly on a hard surface, strainer allows water to be removed down to 1mm
- A peripheral diaphragm type check valve right above the strainer prevents loss of water when the pump is lifted or stopped
- The pump's bottom plate has rubber all-around it, it cannot damage delicate surfaces

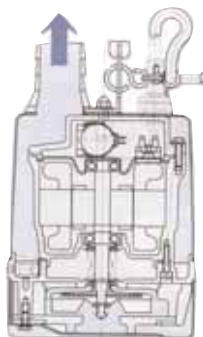

Pumped water cools the motor and discharges as illustrated. The motor can be cooled even when pumping a small amount of water. The top discharge arrangement allows access into areas with space limitations.

The pump can be run continuously in air.

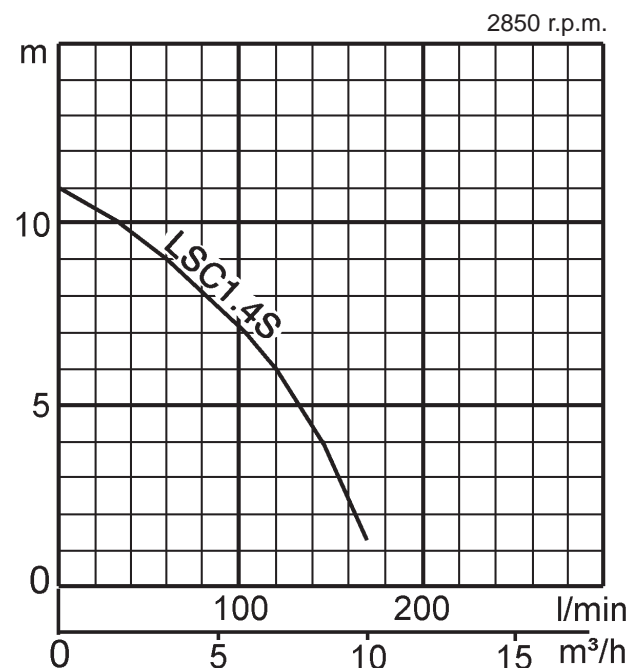

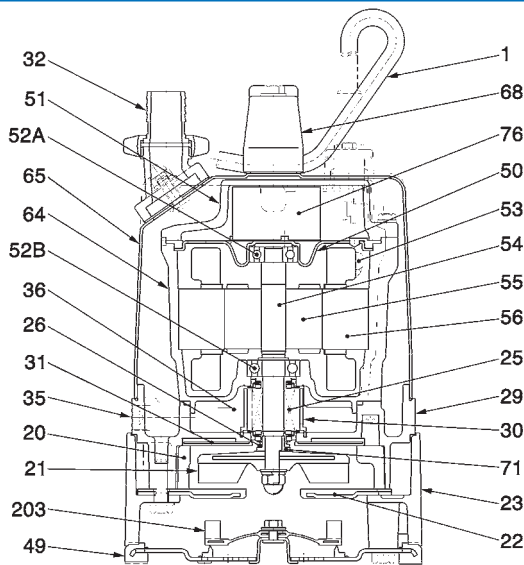

**Standard Accessories:**

- 1 Cable 10m
- 1 Hose band
- 1 ø25mm union and hose coupling

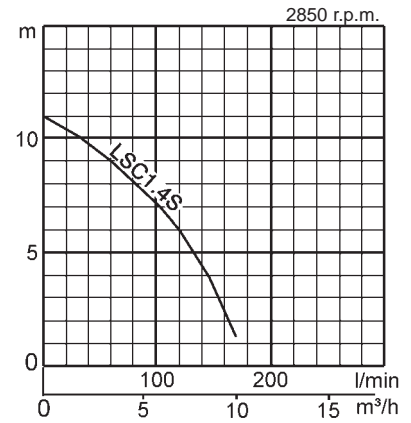

No.	Descriptions	No.	Descriptions
1	Cable	50	Motor Bracket
20	Pump Casing	51	Motor Head Cover
21	Impeller	52A	Upper Bearing
22	Suction Cover	52B	Lower Bearing
23	Stand	53	Motor Protector
25	Mechanical Seal	54	Shaft
26	V-Ring	55	Rotor
29	Oil Casing	56	Stator Complete
30	Oil Lifter	64	Motor Frame
31	Wearing Plate	65	Outer Cover
32	Hose Coupling	68	Handle
35	Oil Plug	71	Shaft Sleeve
36	Lubricant	76	Capacitor
49	Bottom Plate	203	Check Valve

Model	Bore mm	Motor output kW	Rated current A 230V/110V	Max. head m	Max. capacity l/min	Dry weight kg	Max. solid handling mm	Max. water depth m
LSC1.4S	25	0,48	2,9/6,2	11	170	12	6	20

Dry weight of the pump without cable

Discharge bore mm		25	<b>LSC</b>	
<b>Pumping Fluid</b>	Type of Fluid	Cleaning water, Water on floor, Puddles		
	Liquid Temperature	0 - 40°C		
<b>Pump</b>	Components	Impeller	Semi-vortex type	
		Shaft Seal	Double mechanical seal	
		Bearing	Shielded ball bearings	
	Material	Impeller	Urethane rubber	
		Casing	Ethylene propylene rubber	
		Suction Cover	Steel plate + urethane rubber	
Shaft Seal (mechanical Seal)	Silicon carbide in oil bath			
<b>Motor</b>	Type, Poles	Dry-type submersible induction motor, 2 poles		
	Insulation	Insulation class E		
	Phase / Voltage	Single phase / 230V/110V		
	Motor Protector (built-in)	Circle thermal cut-out		
	Lubricant	Turbine oil (ISO VG32)		
	Material	Frame	Aluminium die casting	
		Shaft	Stainless steel EN-X6Cr13	
Cable		Rubber, H07RN-F		
<b>Discharge Connection</b>		Hose coupling		

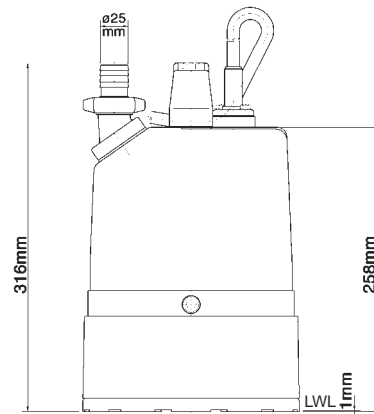
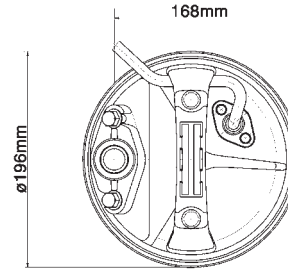

LWL: lowest running water level

LSC1.4S-51

We reserve the right to change specifications and designs herein for improvement without prior notice. Our pumps are for professional use only. In the event that Tsurumi (Europe) GmbH have, in exceptional cases taken over, a manufacturer's warranty, this entitles the end-user to assert remedy free of charge against Tsurumi (Europe) GmbH due to any defect to the product occurring during the guarantee period (see below), also then when the warranty claims against the seller do not or no longer exist. In the event of malfunction, which is attributable to the improper handling by the enduser, no guarantee claim shall arise. Further claims shall not result from the warranty, unless if something to the contrary has explicitly been determined. The decision as to whether remedy is effected by way of replacement or repair shall be at the choice of Tsurumi (Europe) GmbH. The claims shall be time barred after a period of three months after expiry of the guarantee period, however, not before expiry of the warranty period which is valid towards the seller. In the event of doubt, the warranty period shall correspond with the warranty period which is valid between the end-user and his seller.

# Tsurumi (Europe) GmbH

Heltorfer Straße 14  
 D-40472 Düsseldorf  
 Tel.: +49-211-4179373  
 Fax: +49-211-4791429  
 Email: sales@tsurumi-europe.com  
 www.tsurumi-europe.com

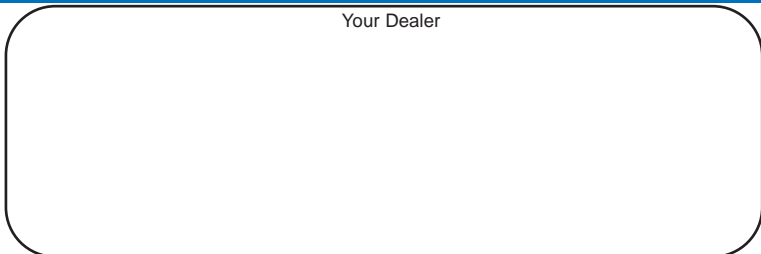

Your Dealer