



# varisco®

a solid name in fluids



**pompe centrifughe autoadescanti**  
**self-priming centrifugal pumps**  
**pompes centrifuges auto-amorçantes**  
**selbstansaugenden Kreiselpumpen**

# E

# 1 1/2"

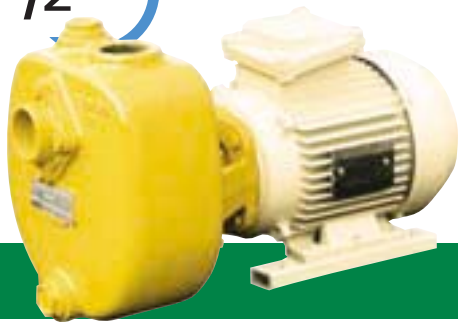

## E 30-160 2.2 kW

Passaggio corpi solidi

Solids handling

Passage corps solides

Durchmesser der Feststoffe

(Motopompe - Engine driven pumps)

Motopompen - Pumpen mit Verbrennungsmotoren)

8 mm

6 mm

Rif. / Ref. B4.0221 (Rev. 00)

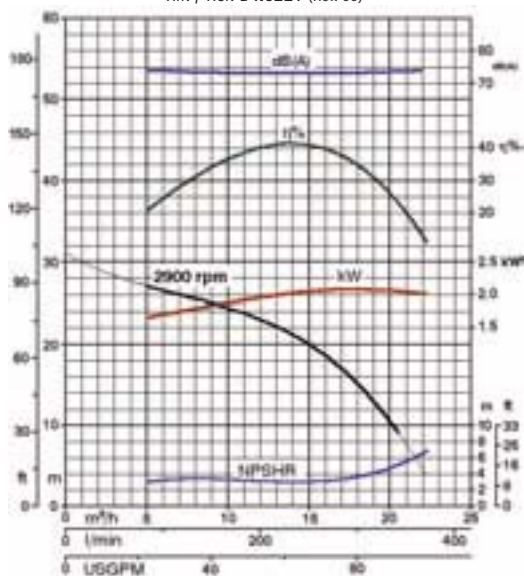

Rif. / Ref. B4.0223 (Rev. 00)

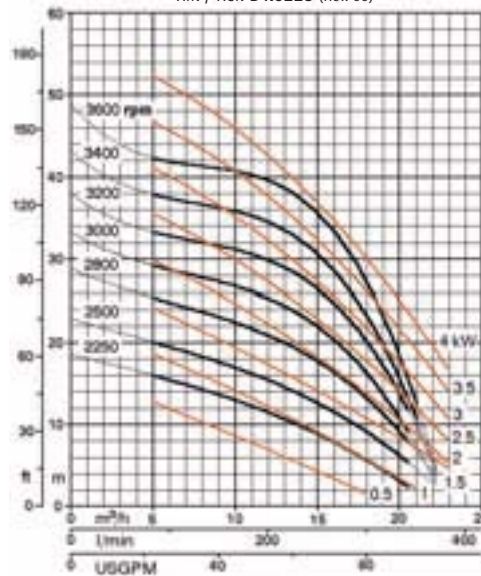

Marca Make Marque Marke	Modello Type Type Typ	Estensione albero Shaft extension Extrémité d'arbre Wellenverlängerungen	Estensione VARISCO VARISCO extension Extrémité VARISCO VARISCO Wellenverlängerungen	Cilindrata Capacity Cylindr. Hubraum cm <sup>3</sup>	Potenza Power Puissance Leistung kW (DIN 6270)	Giri/min RPM tr/mn Drehzahl	Serbatoio Fuel tank Réservoir Tankinhalt l	Peso Weight Poids Gewicht kg
Motori a benzina <i>Petrol (gasoline) engines</i> Moteurs à essence <i>Benzinmotoren</i>								
Acme	A 220 B	STD	F	220	2.9	3600	3.2	43
Acme	AT 220 OHV	STD	F	220	3.8	3600	3.6	44
Acme	ALN 330 WB	STD	F	327	4.7	3600	4	49
Briggs & Str.	133432	495644	C	206	3.1	3600	3.8	44
Honda	GX 160 K1	T	C	163	3.6	3600	3.6	41
Intermotor	IM 250	STD	F	254	3.7	3600	4.2	49
Intermotor	LGA 226	STD	F	220	4.4	3600	3.1	44
Mitsubishi	GM 180	A02-a / A02-b / A03-a	C / X / A	181	3.3	3600	4	44
Ruggerini	RS 7.0	STD	F	285	4.2	3600	3.3	50
Motori diesel <i>Diesel engines</i> Moteurs diesel <i>Dieselmotoren</i>								
Acme	ADX 300	STD	*	301	4.4	3600	4.5	64
Lister	AC1	CA+BJ1	C	304	4.8	3600	5.1	73
Lombardini	15 LD 315	STD	F	315	4.1	3600	4.3	59
Ruggerini	MD 75.1	STD	F	327	4.4	3600	4	69

\* Solo accoppiamento a supporto *Only long coupled* Seulement accouplement en ligne *Nur mit Lagerbockausführung*

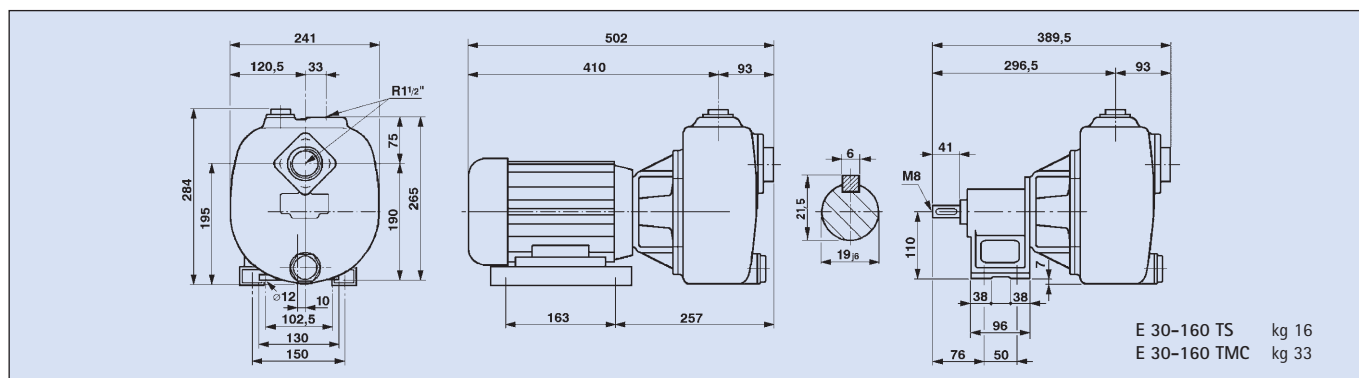

# 2"



# E 50

# 1.1 kW

Passaggio corpi solidi  
Solids handling  
Passage corps solides  
Durchmesser der Feststoffe

17 mm

Rif. / Ref. B4.0506 (Rev. 00)

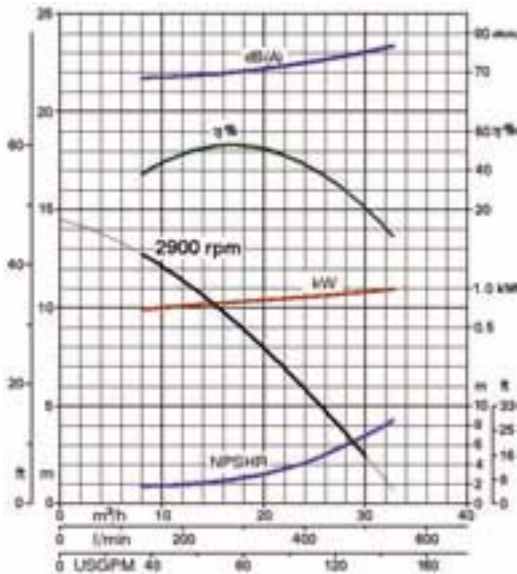

Rif. / Ref. B4.0508 (Rev.01)

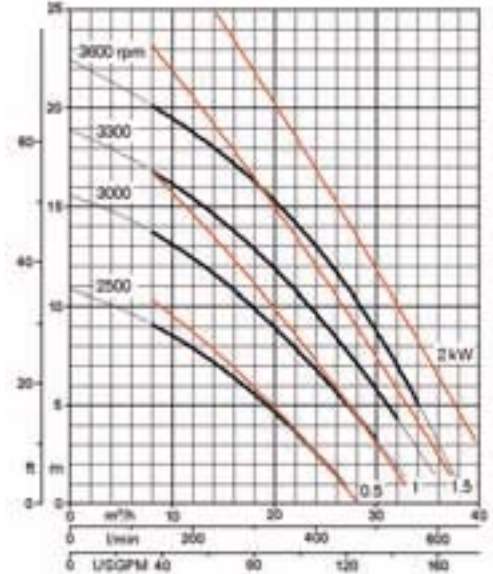

Marca Make Marque Marke	Modello Type Type Typ	Estensione albero Shaft extension Extrémité d'arbre Wellenverlängerungen	Estensione VARISCO VARISCO extension Extrémité VARISCO VARISCO Wellenverlängerungen	Cilindrata Capacity Cylindrée Hubraum cm <sup>3</sup>	Potenza Power Puissance Leistung kW (DIN 6270)	Giri/min RPM tr/mn Drehzahl	Serbatoio Fuel tank Réservoir Tankinhalt l	Peso Weight Poids Gewicht kg	Dimensioni Dimensions Encombres Abmessungen		
									B2	B4	H2
<b>Motori a benzina Petrol (gasoline) engines Moteurs à essence Benzinmotoren</b>											
Acme	A 180 B	STD	F	179	2.6	3600	3.2	27	450	350	510
Briggs & Str.	93432	495210	C	148	2.25	3600	3.0	25	450	350	510
Honda	GX 120 K1	T	C	118	2.9	3600	2.5	23	450	350	510
Intermotor	IM 250	STD	F	254	3.7	3600	4.2	33	450	350	510
Intermotor	LGA 226	STD	F	220	4.4	3600	3.1	28	450	350	510
Mitsubishi	GM 130	A02-a / A02-b / A03-a	C / X / A	126	2.0	3600	3.0	25	450	350	510
Tecnamotor	BM 153 P	STD	A	148	2.6	3650	1.2	21	450	350	510
Robin	EY 15 DP	DP / DP 5/8"	X / C	143	2.0	3600	2.8	23	450	350	510
Ruggerini	RS 4.5	STD	F	179	2.6	3600	2.3	23	450	350	510
<b>Motori diesel Diesel engines Moteurs diesel Dieselmotoren</b>											
Acme	ADX 300	STD	*	301	4.4	3600	4.5	61	Su carrello on trailer sur chariot auf Fahrgestell		
Lombardini	15 LD 225	STD	F	224	3.1	3600	3	51			
Lombardini	15 LD 315	STD	F	315	4.1	3600	4.3	56			
Ruggerini	MD 75.1	STD	F	327	4.4	3600	4	66			
Ruggerini	MICRO 50	STD	F	260	2.8	3600	3.8	50			

\* Accoppiamento speciale Special coupling Accouplement spécial Sonderkupplung

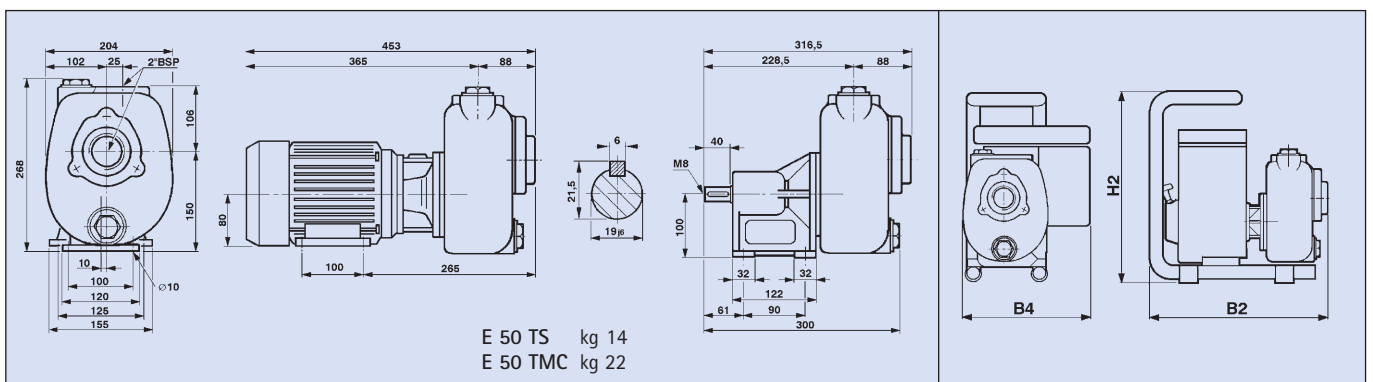





# Caratteristiche Specifications Caractéristiques Merkmale

 Corpo e girante in ghisa  
Tenuta meccanica autolubrificante

Bocche filettate BSP (a richiesta NPT)

Versioni: a supporto, a monoblocco con motore elettrico,  
a monoblocco con motore endotermico

 Cast iron casing and impeller  
Self-lubricating mechanical seal

BSP tapped ports (NPT on request)

Versions: Pedestal, close-coupled electric motor,  
close-coupled engine driven

 Corps et turbine en fonte  
Garniture mécanique simple

Orifices taraudés BSP (NPT sur requête)

Versions: à palier, monobloc avec moteur électrique,  
monobloc avec moteur thermique

 Gehäuse und Laufrad aus Grauguß  
Gleitringdichtung

Gewindeanschluß BSP, (auf Anfrage, NPT),

Ausführung: mit Lagerbock, mit Elektromotor,  
mit Verbrennungsmotor

## Estensioni alberi disponibili Shaft extensions available

## Extremités d'arbre disponibles Verfügbare Wellenverlängerungen

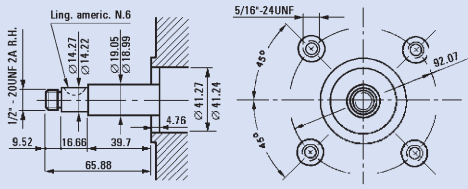
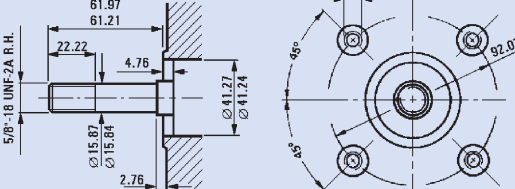
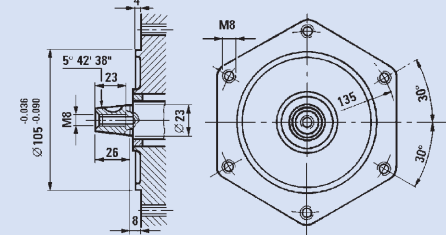
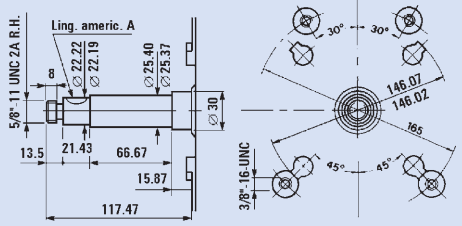
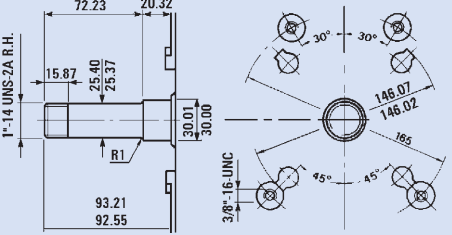
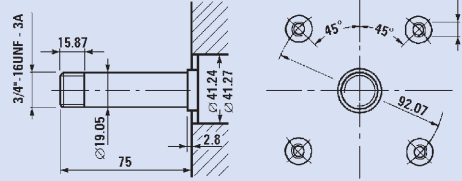
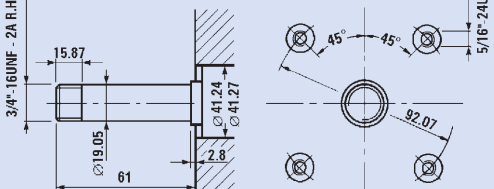
<p><b>A</b></p> <p>E50 E75</p> 	<p><b>C</b></p> <p>E30-160 E50 E75</p> 
<p><b>F</b></p> <p>E30-160 E50 E75 E100</p> 	<p><b>H</b></p> <p>E100</p> 
<p><b>G</b></p> <p>E100</p> 	<p><b>N</b></p> <p>E50 E75</p> 
<p><b>X</b></p> <p>E50 E75</p> 	

I dati e le caratteristiche citati sul presente stampato non sono impegnativi. Il costruttore si riserva il diritto di apportare qualsiasi modifica senza alcun preavviso. / The specifications, illustrations and data in this leaflet are not binding. The makers reserve the right to carry out modifications at any time without notice. / Le constructeur se réserve le droit d'apporter des modifications aux descriptions et illustrations sans préavis. / Abbildung und Maße unverbindlich. Technische Änderungen vorbehalten.

**VARISCO®**  
a solid name in fluids

**VARISCO S.p.A.**

Zona Industriale Nord - 35129 PADOVA - Italy

Direzione e uffici: Terza Strada, 9

Produzione e magazzini: Prima Strada, 37

Tel. 049 82 94 111

Telefax 049 82 94 373

e-mail [italia@variscospa.com](mailto:italia@variscospa.com)

Web site [www.variscospa.com](http://www.variscospa.com)

+39 049 82 94 111

+39 049 80 76 762

[export@variscospa.com](mailto:export@variscospa.com)

**Filiale di Roma**

Via S. Leo, 36

00138 ROMA - Italy

Tel. 06 88 12 682

Fax 06 88 12 654

e-mail [roma@variscospa.com](mailto:roma@variscospa.com)