

ISTRUZIONI PER L'INSTALLAZIONE E LA MANUTENZIONE
INSTRUCTIONS DE MISE EN SERVICE ET D'ENTRETIEN
INSTRUCTIONS FOR INSTALLATION AND MAINTENANCE
INSTALLATIONSANWEISUNG UND WARTUNG
INSTRUCTIES VOOR INGEBRUIKNAME EN ONDERHOUD
INSTRUCCIONES PARA LA INSTALACION Y EL MANTENIMIENTO
INSTALLATIONS - OCH UNDERHÅLLSANVISNING
KULLANIM VE BAKIM TALİMATLARI

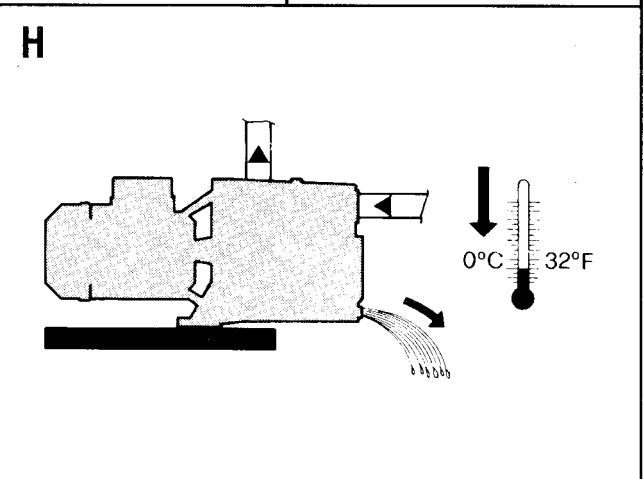
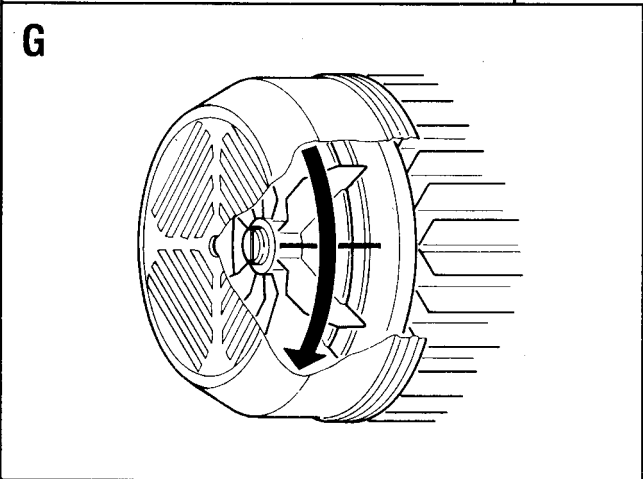
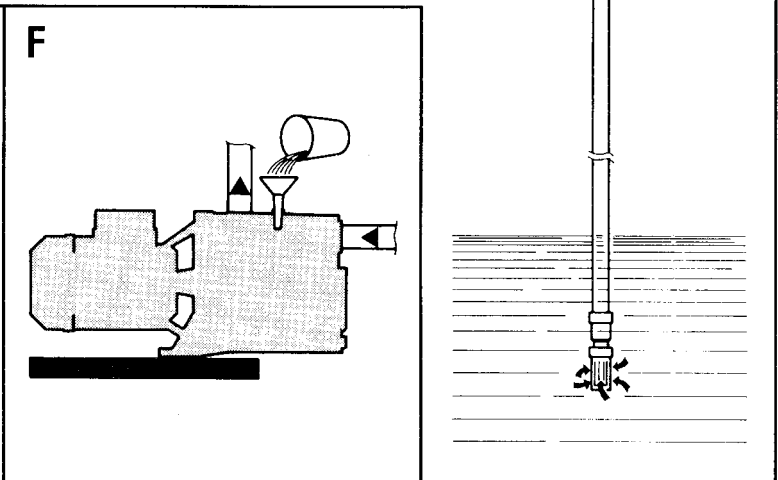
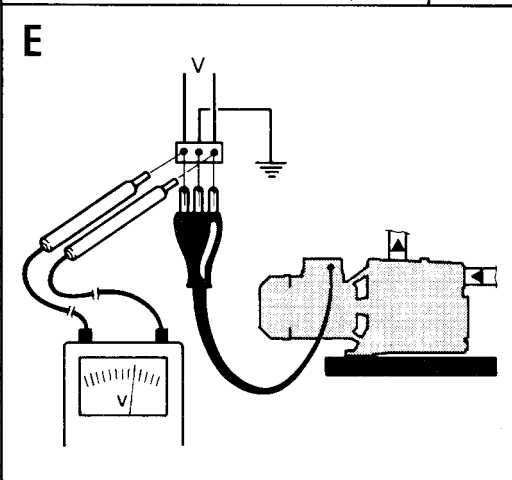
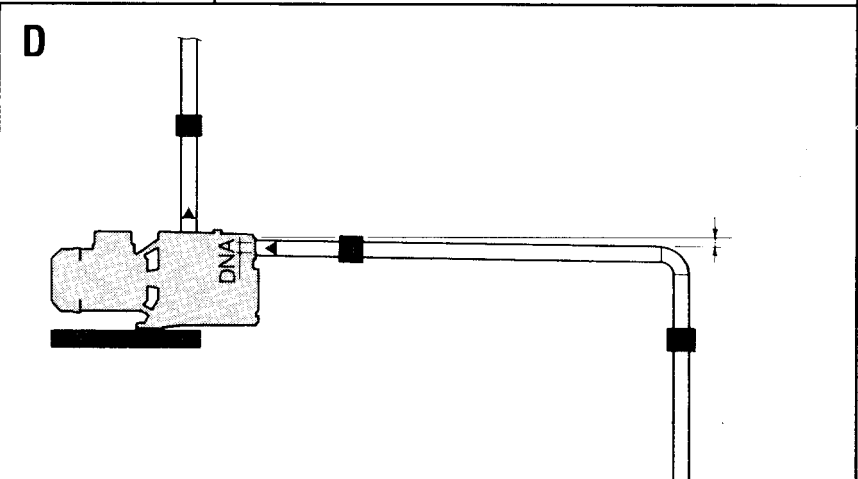
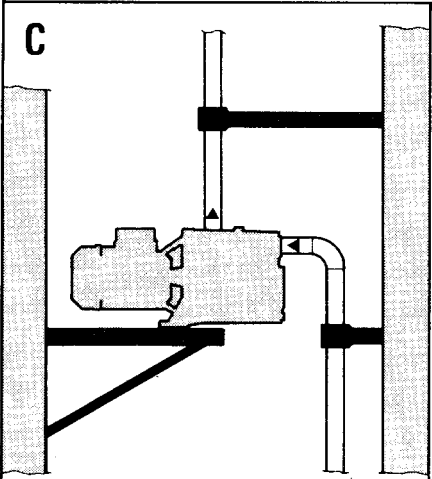
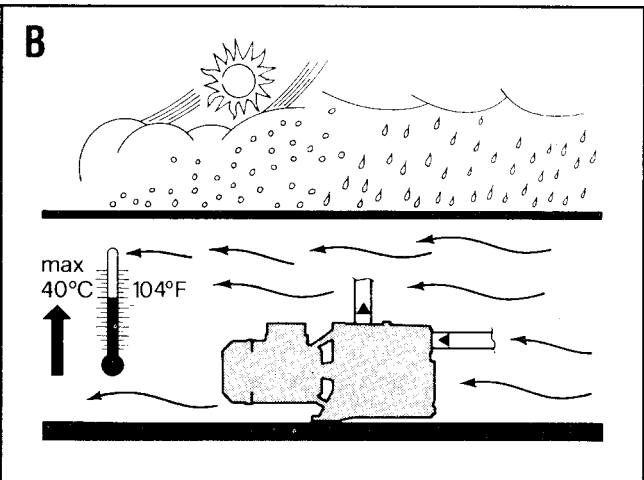
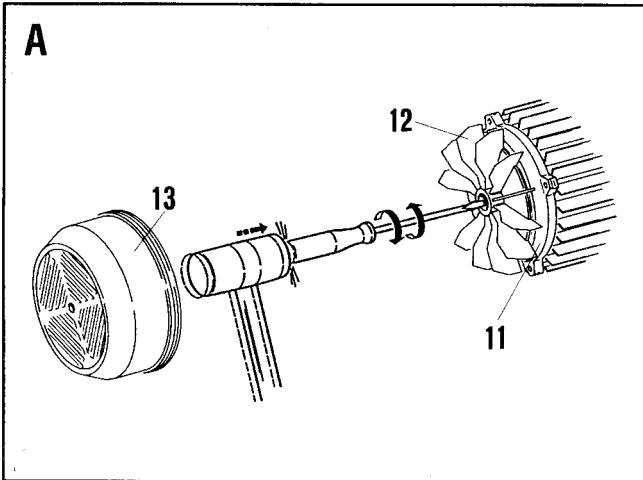

JET 61 - JET 61 M-P - GARDENJET 61
JET 81 - JET 81 M-P - GARDENJET 81
JET 100 - JET 100 M-P - GARDENJET 100

JET 200 - JET 300

DP 80 - DP 81 - DP 100
DP 151 convertibili - DP 251 convertibili
JET 151 convertibili - JET 251 convertibili

NOVAGARDEN

JETINOX 90 - JETINOX 110
JETINOX 90 M-P - JETINOX 110 M-P
GARDEN-INOX 90 M - GARDEN-INOX 110 M

K-INOX 30/30 - K-INOX 30/30 M-P

EURO 25/30 - EURO 30/30 - EURO 40/30
EUROINOX 25/30 - EUROINOX 30/30 - EUROINOX 40/30
EURO 30/50 - EURO 40/50 - EURO 50/50
EUROINOX 30/50 - EUROINOX 40/50 - EUROINOX 50/50
EURO 25/80 - EURO 30/80 - EURO 40/80
EUROINOX 25/80 - EUROINOX 30/80 - EUROINOX 40/80

K 20/41 - K 30/70 - K 30/100 - K 36/100
K 12/200 - K 14/400
K 35/40 - K 45/50 - K 55/50
K 35/100 - K 40/100

KP 30/16 – KP 38/18 - KP 60/6 - KP 60/12 - KPA 40/20

DICHIARAZIONE DI CONFORMITÀ

La Ditta DAB PUMPS s.p.a. - Via M. Polo,14 - Mestrino (PD) - ITALY - sotto la propria esclusiva responsabilità dichiara che i prodotti summenzionati sono conformi a:

- Direttiva del Consiglio del 14 giugno 1989 n° 89/392 concernente il riavvicinamento delle legislazioni degli Stati membri CEE relative alle macchine e successive modifiche.
- Direttiva della Compatibilità elettromagnetica 89/336 e successive modifiche.
- Direttiva Bassa Tensione 73/23 e successive modifiche.

DECLARATION OF CONFORMITY

The Company DAB PUMPS s.p.a. - Via M. Polo,14 - Mestrino (PD) - ITALY - declares under its own responsibility that the above-mentioned products comply with:

- Council Directive no. 89/392 of 14 June 1989 concerning the reconciliation of the legislations of EEC Member Countries with relation to machines and subsequent modifications .
- Directive on electromagnetic compatibility no. 89/336 and subsequent modifications .
- Directive on low voltage no. 73/23 and subsequent modifications .

CONFORMITEITSVERKLARING

De firma DAB PUMPS s.p.a. - Via M. Polo, 14 Mestrino (PD) - Italië, verklaart hierbij onder haar verantwoording dat hierbovengenoemde produkten conform zijn aan

- de Richtlijn van de Raad van 14 juni 1989 nr. 89/372 betreffende harmonisatie van de wetgeving in de EEG-lidstaten t.a.v. machines en daaropvolgende wijzigingen.
- De richtlijnen van de elektromagnetische overeenstemming 89/336 en latere veranderingen.
- De richtlijnen voor lage druk 73/23 en latere veranderingen.

FÖRSÄKRAN OM ÖVERENSSTÄMMELSE

Bolaget DAB PUMPS s.p.a. - Via M. Polo,14 - Mestrino (PD) - ITALIEN - intyggar på eget ansvar att ovan nämnda produkter är i enlighet med:

- Rådets direktiv av den 14 juni 1989 nr. 89/392 och efterföljande ändringar som innehåller en jämkning av EU-ländernas lagstiftning beträffande maskiner.
- EMC-direktivet nr. 89/336 och efterföljande ändringar.
- Lågspänningsdirektiv nr. 73/23 och efterföljande ändringar.

Mestrino (PD), 07 Gennaio 1998

DÈCLARATION DE CONFORMITÈ

L'entreprise DAB PUMPS s.p.a. - Via M. Polo,14 - Mestrino (PD) - ITALIE - déclare sous sa responsabilité exclusive que les produits susmentionnés sont conformes à:

- la Directive du Conseil du 14 juin 1989 n° 89/392 concernant l'harmonisation des législations des Etats membres de la CEE relatives aux machines et ses modifications successives .
- la Directive de la compatibilité électromagnétique 89/336 et ses modifications successives .
- la Directive basse tension 73/23 et ses modifications successives.

KONFORMITÄTSEKTLÄRUNG

Die Firma DAB PUMPS s.p.a. - Via M. Polo,14 - Mestrino (PD) - ITALY - erklärt unter ihrer eigenen, ausschließlichen Verantwortung, daß die genannten Produkte den folgenden Verordnungen entsprechen:

- Ratsverordnung Nr. 89/392 vom 14. Juni 1989 über die Angleichung der Gesetzgebung der CEE-Staaten über Maschinen und folgende Abänderungen
- Verordnung über die elektromagnetische Kompatibilität 89/336 und folgende Abänderungen.
- Verordnung über Schwachstrom 73/23 und folgende Abänderungen.

DECLARACION DE CONFORMIDAD

La Empresa DAB PUMPS s.p.a. - Via M. Polo,14 - Mestrino (PD) - ITALY - bajo su propia y exclusiva responsabilidad declara que los productos anteriormente mencionados respetan:

- Las Directrices del Consejo del 14 de junio de 1989 n° 89/392 referentes a la homogeneización de las legislaciones de los Estados miembros de la CEE relativas a las máquinas y sucesivas modificaciones
- Directriz de la Compatibilidad electromagnética 89/336 y sucesivas modificaciones
- Directriz Baja Tensión 73/23 y sucesivas modificaciones

UYGUNLUK BEYANI

Via M. Polo, 14 - Mestrino (PD) - İTALYA'da bulunan DAB PUMPS S.p.A., kendi sorumluluğunu üstüne alarak yukarıda belirtilen ürünlerin

- AET üyelerinin makinelerle ilgili normlar ile ilişkin tamamlamalarının uyumlaştırılmasına ait olan 14 haziran 1989 tarihli, 89/392 sayılı Avrupa Konseyi Yönetmeliğine
- 89/336 sayılı AET Elektromanyetik Uyum Yönetmeliği ile ilişkin tamamlamalarına
- 73/23 sayılı AET Alçak Gerilim Yönetmeliği ile ilişkin tamamlamalarını uygun olduklarını beyan eder.



Attilio Conca
Legale Rappresentante
Legal Representative



The machine has been designed and built for pumping water, free from explosive substances and solid particles or fibres, with a density of 1000 kg/m³ and a kinematic viscosity of 1 mm²/s, and chemically non-aggressive liquids.

4. TECHNICAL DATA AND RANGE OF USE

- **Supply voltage:** 220 - 240V 50Hz
110V 50Hz
115V 60Hz
230V 60Hz
230 V3 – 400 V3 50/60Hz | see electrical data plate
- **Absorbed power:** see electrical data plate
- **Delivery:** from 0,06 to 37 m³/h
- **Head up:** to 102 m.
- **Pumped liquid:** clean, free from solid bodies or abrasive substances, non-aggressive.
- **Degree of motor protection:** IP44 (For IP55 see plate on package)
- **Degree of terminal board protection:** IP55 (IP44 for KP 30/16)
- **Protection class:** F
- **Cable clamp:** PG 11 and/or PG 13.5, depending on models
- **Line fuses AM class:**

Model	Line fuses(Amps)			
	110V 50Hz 115V 60Hz	220-240V 50Hz 230V 60Hz	230 V3 50/60Hz	400 V3 50/60Hz
KP 30/16; KP 30/16 Pred.; NOVAGARDEN	6	4	2	2
KP 38/18; KP 38/18 Pred.; KP 60/6; JET 61; JET 61 M-P.; DP 81; GARDENJET 61; JET 81; JET 81 M-P.; GARDENJET 81; K 20/41;	8	4	4	2
JETINOX 90; JETINOX 90 M-P; GARDEN-INOX 90 M; K-INOX 30/30; K-INOX 30/30 M-G.; KPA 40/20 ;	8	6	4	2
KP 60/12;	--	6	4	4
EURO-EUROINOX 40/30 – 30/50 – 25/80;	10	6	4	4
EURO-EUROINOX 25/30 – 30/30;	8	4	4	4
EURO-EUROINOX 40/50 – 30/80;	12	6	6	4
EURO-EUROINOX 50/50 – 40/80;	20	8	6	4
DP 80;	12	6	4	2
JET 100; JET 100 M-P; GARDENJET 100; K 12/200; K 30/70; K 35/40; DP 100;	12	6	6	4
JETINOX 110; JETINOX 110 M-P; GAREDEN-INOX 110 M; K 30/100;	16	8	6	4
JET 151; K 35/100;	20	10	6	4
K 40/100; K 36/100; K45/50; DP 151;	20	10	8	4
JET 200; K 14/400;	20	10	8	6
JET 251;	25	12	8	6
JET 300; K 55/50; DP 251;	32	16	10	6
Maximun operating pressure:	4,5 bar (450 kPa):	NOVAGARDEN		
	6 bar (600 kPa):	JET 61, JET 81, JET 100 and derived; K-INOX 30/30 and derived; KP 30/16; DP 80; DP 81; DP 100; EURO; EUROINOX and derived; K 35/40;K 35/100; K 40/100; K 20/41; K 30/70; K 30/100; K 36/100; K 12/200; K 14/400;		
	7,5 bar (750 kPa):	JET 151, JET 251; JET 200; JET 300; DP 151; DP 251;		
	8 bar (800 kPa):	JETINOX 90, JETINOX 110 and derived; K 45/50; K 55/50;		
	10 bar (1000 kPa):	KP 60/6; KP 60/12; KPA 40/20 ; KP 38/18		
Liquid temperature range:	0 ÷ +35°C:	For all homologated pumps EN 60335-2-41 (for domestic uses)		
	0 ÷ +40°C:	JET 151, JET 251, JET 200, JET 300, DP 80, DP 81, DP 100, DP 151, DP 251,		
	-10 ÷ +50°C:	K 20/41, K 30/70, K 30/100, K 36/100, K 12/200,		

	K 35/40, K 45/50, K 35/100, K 40/100; KP 30/16; KP38/18
-10 ÷ +80°C:	KP 60/6, KP 60/12 ; KPA 40/20 ;
-15 ÷ +110°C:	K 14/400, K 55/50,

- **Storage temperature:** -10°C to +40°C
- **Relative humidity of the air:** MAX. 95%
- **Noise level:** Falls within the limits envisaged by EC Directive 89/392/EEC and subsequent modifications.
- Motor construction in conformity with standards CEI 2-3 - CEI 61-69 (EN 60335-2-41)

5. MANAGEMENT

5.1 Storage

All the pumps must be stored indoors, in a dry, vibration-free and dust-free environment, possibly with constant air humidity.

They are supplied in their original packaging and must remain there until the time of installation. If this is not possible, the intake and delivery aperture must be accurately closed.

5.2 Transport

Avoid subjecting the products to needless jolts or collisions.

To lift and transport the unit, use lifting equipment and the pallet supplied standard (if applicable).

5.3 Weights

The adhesive label on the package indicates the total weight of the electropump.

6. WARNINGS

6.1 Skilled technical personnel



It is advisable that installation be carried out by skilled personnel in possession of the technical qualifications required by the specific legislation in force.

The term **skilled personnel** means persons whose training, experience and instruction, as well as their knowledge of the respective standards and requirements for accident prevention and working conditions, have been approved by the person in charge of plant safety, authorizing them to perform all the necessary activities, during which they are able to recognize and avoid all dangers. (Definition for technical personnel IEC 364).

6.2 Safety

Use is allowed only if the electric system is in possession of safety precautions in accordance with the regulations in force in the country where the product is installed (for Italy, CEI 64/2).

6.3 Checking motor shaft rotation

Before installing the pump you must check that the rotating parts turn freely. For this purpose remove the fan cover (13) from its seat in the motor end cover (11). Insert a screwdriver in the notch on the motor shaft from the ventilation side. If there is a blockage, turn the screwdriver, tapping it gently with a hammer. **FIG. A**

A

6.4 Responsibility



The Manufacturer does not vouch for correct operation of the pumps if they are tampered with or modified, run outside the recommended work range or in contrast with the other instructions given in this manual.

The Manufacturer declines all responsibility for possible errors in this instructions manual, if due to misprints or errors in copying. The company reserves the right to make any modifications to products that it may consider necessary or useful, without affecting the essential characteristics.

7. INSTALLATION

- 7.1 The electropump must be fitted in a well ventilated place, protected from unfavourable weather conditions and with an environment temperature not exceeding 40°C. Fig.B
- 7.2 A firm anchoring of the pump to the bearing surface favours the absorption of any vibrations caused by pump operation. **Fig. C**
- 7.3 Ensure that the metal pipes do not exert undue strain on the apertures, thus preventing deformations or breakages. **Fig. C**
- 7.4 **It is always good practice to place the pump as close as possible to the liquid to be pumped.** The pump must be installed only in horizontal position. The internal diameters of the pipes must

never be smaller than that of the mouth of the electropump. It is advisable to fit a foot valve on suction. **Fig. D** For suction depths of over four metres or with long horizontal stretches it is advisable to use an intake hose with a diameter larger than that of the intake aperture of the pump. To prevent the formation of air pockets, the intake hose must slope slightly upwards towards the pump. **Fig. D**

- 7.5 If the intake pipe is made of rubber or flexible material, always check that it is of the reinforced type to avoid throttling due to suction.
- 7.6 NOVAGARDEN electropumps must be connected to the pipe **exclusively by means of flexible couplings** so that the weight of the pipes does not bear down on the pump.
- 7.7 The lifting and carrying handle **must always be present and well fixed to the support** on all pumps produced in the portable version.

8. ELECTRICAL CONNECTION

Caution! always follow the safety regulations.



Scrupulously follow the wiring diagrams inside the terminal board box.

- 8.1 **Electric installation must be carried out by skilled and authorized electrician who accepts all the responsibility for the job.**
- 8.2 Ensure that the mains voltage is the same as the value shown on the motor plate and that there is the possibility of **MAKING A GOOD EARTH CONNECTION. Fig. E**
- 8.3 In fixed installations, International Safety Standards require the use of isolating switches with a fuse-carrier base.
- 8.4 Single-phase motors are provided with built-in thermal overload protection and may be connected directly to the mains. Three-phase motors must be protected with special remote-control motor-protectors calibrated for the current shown on the plate.

9. STARTING UP

9.1



Do not start the pump unless it has been completely filled with fluid.

Before starting up, check that the pump is properly primed; fill it completely with clean water by means of the hole provided after having removed the filler cap on the pump body. This ensures that the mechanical seal is well lubricated and that the pump immediately starts to work regularly. (**Fig. F**). **Dry operation causes irreparable damage to the mechanical seal.** The filling cap must then be screwed back on carefully.

- 9.2 Switch on the power and check, on the three-phase version, that the motor is turning in the correct direction; this should be in a clockwise direction, looking at the motor from the impeller side. **Fig. G** If it is turning in the wrong direction, invert the connections of any two wires on the terminal board, after having disconnected the pump from the power mains.

10. PRECAUTIONS

- 10.1 The electropump should not be started more than 20 times in one hour so as not to subject the motor to excessive thermal shock.
- 10.2 **DANGER OF FROST:** When the pump remains inactive for a long time at temperatures of less than 0°C, the pump body must be completely emptied through the drain cap (26) **Fig. H**, to prevent possible cracking of the hydraulic components. This operation is advisable even in the event of prolonged inactivity at normal temperature.
- 10.3 When starting after long periods of inactivity, the starting-up operations listed above must be repeated.

11. MAINTENANCE AND CLEANING



In normal operation, the pump does not require any specific maintenance. However, it may be necessary to clean the hydraulic parts when a fall in yield is observed. **The electropump must not be dismantled unless by skilled personnel in possession of the qualifications required by the regulations in force.** In any case, all repairs and

maintenance jobs must be carried out only after having disconnected the pump from the power mains.

12. MODIFICATIONS AND SPARE PARTS



Any modification not authorized beforehand relieves the manufacturer of all responsibility. All the spare parts used in repairs must be original ones and the accessories must be approved by the manufacturer so as to be able to guarantee maximum safety of the machines and systems in which they may be fitted.



In the event of damage to the power cable of this appliance, the repair must be carried out by skilled personnel, in order to prevent all risks.

12.1 Removal and replacement of the supply cable

Before starting, ensure that the electropump is not connected to the power network.

A) For versions without a pressure switch

Remove the condenser cover (92), unscrewing the four screws (53) on it. Unscrew the three terminals L - N -⊕ and disconnect the brown lead, the blue lead and the yellow-green lead, coming from the supply cable, after having slackened the grommet (84).

B) For versions with a SQUARE D pressure switch

- **Section of cable with plug from the pressure switch:** unscrew the screw from the cover of the pressure switch using a screwdriver and remove the cover. Remove the yellow-green lead, slackening the earth screw, the blue lead and the brown lead from the respective terminals at the side, slackening the screws on the terminals. Remove the cable blocking terminal, slackening the respective screws, and slip off the cable which is now disconnected.
- **Section of cable from the pressure switch to the terminal board:** unscrew the nut from the cover of the pressure switch using a screwdriver and remove the cover. Remove the yellow-green lead, slackening the earth screw, the blue lead and the brown lead from the respective central terminals, slackening the screws on the terminals. Remove the cable blocking terminal, slackening the respective screws, and slip off the cable which is now disconnected. Remove the condenser cover (92), unscrewing the four screws (53) on it. Unscrew the three terminals L - N -⊕ and disconnect the brown lead, the blue lead and the yellow-green lead, coming from the pressure switch, after having slackened the grommet (84).

C) Version with a TELEMECANIQUE / SQUARE D – TELEMECANIQUE / ITALTECNICA pressure switch:

- **Section of cable with plug from the pressure switch:** unscrew the screw from the cover of the pressure switch using a screwdriver and remove the cover, releasing it from the base of the pressure switch. Slip out the yellow-green lead, unscrewing the earth screw on the left side. Still on the same side, slip the blue lead and the brown lead off their terminals, slackening the screws on the terminals. Slacken the cable clamping nut of the pressure switch on the left side and slip off the cable which is now disconnected.
- **Section of cable from the pressure switch to the terminal board:** unscrew the nut on the cover of the pressure switch using a screwdriver and remove the cover, releasing it from the base of the pressure switch. Slip out the yellow-green lead, unscrewing the earth screw on the right side. Still on the same side, slip the blue lead and the brown lead off their terminals, slackening the screws on the terminals. Slacken the cable clamping nut of the pressure switch on the right side and slip off the cable which is now disconnected. Remove the terminal board cover (92), unscrewing the four screws (53) on it. Unscrew the three terminals L - N -⊕ and disconnect the brown lead, the blue lead and the yellow-green lead, coming from the supply pressure switch, after having slackened the grommet (84).

When replacing the power cable, a cable of the same type must be used (e.g. H05 RN-F or H07 RN-F depending on the installation) and with the same terminals, proceeding as for disassembly in inverse order.

ATTENTION: depending on the installation and if the pumps have no cable, fit supply cables type H05 RN-F for indoor use and type H07 RN-F for outdoor use, complete with plug (standards 61-69). For power cables without a plug, provide a device for cutting off the mains (e.g. magnetothermal device) with separating contacts of at least 3 mm for each pole.

13. TROUBLESHOOTING

FAUL	CHECKS (possible cause)	REMEDY
1. The motor does not start and makes no noise	A. Check the electric connections. B. Check that the motor is live. C. Check the protection fuses.	C. If they are burnt-out, change them. N.B. If the fault is repeated immediately this means that the motor is short circuiting.
2. The motor does not start but makes noise.	A. Ensure that the mains voltage is the same as the value on the plate. B. Ensure that the connections have been made correctly. C. Check that all the phases are present on the terminal board. (3~) D. Look for possible blockages in the pump or motor. E. Check the condition of the capacitor.	B. Correct any errors. C. If not, restore the missing phase. D. Remove the blockage. E. Replace the capacitor.
3. The motor turns with difficulty.	A. Check the voltage which may be insufficient. B. Check whether any moving parts are scraping against fixed parts.	B. Eliminate the cause of the scraping.
4. The pump does not deliver.	A. The pump has not been primed correctly. B. On three-phase motors, check that the direction of rotation is correct. C. The diameter of the intake pipe is insufficient. D. Blocked foot valve.	B. If necessary, invert the connection of two supply wires C. Replace the pipe with one with a larger diameter. D. Clean the foot valve.
5. The pump does not prime.	A. The intake pipe or the foot valve is taking in air. B. The downward slope of the intake pipe favours the formation of air pockets.	A. Eliminate the phenomenon and prime again. B. Correct the inclination of the intake pipe.
6. The pump supplies insufficient flow.	A. Blocked foot valve. B. The impeller is worn or blocked. C. The diameter of the intake pipe is insufficient. D. On three-phase motors, check that the direction of rotation is correct.	A. Clean the foot valve. B. Remove the obstructions or replace the worn parts. C. Replace the pipe with one with a larger diameter. D. If necessary, invert the connection of two supply wires
7. The pump vibrates and operates noisily.	A. Check that the pump and the pipes are firmly anchored. B. There is cavitation in the pump, that is the demand for water is higher than it is able to pump. C. The pump is running above its plate characteristics.	A. Fix the loose parts more carefully. B. Reduce the intake height or check for load losses. C. It may be useful to limit the flow at delivery.