

4" Submersible Motors

4" Unterwassermotoren

Moteurs immergés 4"

Motori sommersi da 4"

**Motores de instalación
subacuática de 4"**

Motores submersíveis de 4"

— **GB** **D** **F** **I** **E** **P** —

GB Assembly and operating instructions

D Montage und Betriebsanleitung

F Instructions de montage et de service

I Istruzioni per il montaggio e l'uso

E Manual de instrucciones de montaje e servicio

P Manual de Instruções de Montagem e de Serviço

Franklin Electric Europa GmbH
Rudolf-Diesel-Straße 20
D-54516 Wittlich/Germany
Tel. -49 (0) 65 71 / 105 -0
Fax -49 (0) 65 71 / 105 -520
Internet: www.franklin-electric.de



**I. Declaration by the Manufacturer
as defined by Machinery Directive 98/37/EC Annex IIB**

Herewith we declare that 4-Inch Submersible motors with model numbers of the following series:

214...
224...
234...
244...
254...

are intended to be incorporated into machinery covered by this Directive, but must not be put into service until the machinery into which it is to be incorporated has been declared in conformity with the actual provisions of the Directive.

II. Declaration of Conformity

We additionally declare that the above mentioned 4-Inch Submersible motors conform with the provisions of EMC Directive 2004/108/EC and Low Voltage Directive 2006/95/EC.

Applied harmonized standards: EN 60034-1

Applied national standards: NEMA MG1-18.388

A handwritten signature in black ink that reads 'J. A. Weber'.

J. A. Weber
Manager, Engineering Services
Western Hemisphere Water Systems

23 July 2007

1 Guidelines

The Franklin Electric submersible motors are a machine component in accordance with the “machines” EC guideline. You must not commission the motor until you have:

- manufactured a complete machine,
- met the safety requirements stipulated in the applicable EC guidelines and confirmed this by a certificate of conformity.

2 Safety

The 4” submersible motor must only be operated in observance of the following safety regulations:

- Operate the motor only under water (fig. 1/ fig. 2)
- Take into account the implementation limits of motor and units
- Check the electrical system and fusing before switching-on (fig. 3)
- Protect electrical and mechanical danger spots against access
- Vent rising pipe before commissioning in order to avoid water hammers when starting-up
- Provide a check valve in the pump or rising pipe (max. 7 m away from pump) (fig. 4)
- Water temperature with original motor filling not below -3°C , with water filling not below 0°C (fig. 5)
- Maximum water temperature $+30^{\circ}\text{C}$. Higher temperatures only with derated motors (fig. 5)
- With generator operation always unload the generator first, i.e.
 - **Start:** First the generator, then the motor
 - **Switch-off:** First the motor, then the generator
- After powering the system check:
 - operating current of the motor at each phase
 - mains voltage with the motor running
 - level of the medium to be pumped
- Switch off the motor immediately if:
 - Nameplate current is exceeded
 - voltage tolerances of more than $+6\%$ / -10% compared to the rated voltage on the motor are measured (fig. 6)
 - dry run is imminent

3 Intended use

Franklin Electric Submersible Motors are specifically designed for submerged operation as drivers of variable torque loads such as pumps i.e.

- Drinking water supply
- Wells in domestic houses, waterworks and agriculture
- Dewatering, pressure boosting, irrigation systems
- Supply of process water
- Ground water heating systems

Improper use of Franklin Electric Submersible Motors, like pumping of air or explosive media is strictly prohibited.

- Maximum 20 starts per hour, allow 60 seconds between successive starts.
- The maximum submergence depth is 150 meters. Up to 1000 meters after consulting Franklin Electric. Motors in 316 SS are available for operation in aggressive environments. The responsibility for correct material choosing lies with the customer.



Attention

For required motor cooling, please consult motor nameplate etc. If cooling flow is not sufficient, fit an inducer sleeve.

4 Transport and storage



Attention

The motor may be commissioned by trained and instructed personnel only. Electrical connections have only to be carried out by qualified personnel.

- Store motor in original packaging until assembly

- Under no circumstances may the motor be stored at temperatures above 50°C since this can lead to filling liquid leakage and premature motor failure (fig. 7)
- Storage temperature with original motor filling up to -40°C , with water filling frost-free (fig. 8)

5 Connecting the motor cable

- 1 Remove plastic plug on the motor.
- 2 Clear plug and socket of dirt and moisture.
- 3 Apply a bit of silicone grease or vaseline to the rubber part of the plug – pay attention that no grease reaches the electrical contacts.
- 4 Insert plug into the socket until the socket thread becomes visible again.
- 5 Now turn jam nut counter-clockwise until you find the start of thread. Then turn clockwise and tighten it by hand, until compression of the rubber is noticed. Now, use a 19 mm open end spanner to tighten another 1/2 turn.



Attention

The maximum tightening torque of the plug is 20 - 27 Nm. If the jam nut is tightened too much, the plug will become leaky.

- 6 Route the motor leads along the pump and use the cable guard to protect it from damage.

6 Extending the motor cable

The cable provided can be extended by the customer, by one of the following means:

- Apply non-permanent plug connection with Franklin Electric Termination Kit 309 090 901 (or -902 with strain relief)
- Use joints with shrink hose, sealing compound or finished cable fittings. Protect joints against penetrating moisture (strictly follow manufacturer's instructions).



Note

The plumbers themselves are responsible for the correct selection and dimensioning of the drop cable!

- Extension cable must be approved for its use in the medium and the prevailing temperatures.

7 Assembly of motor and unit

These instructions refer to the motor only. Please strictly observe the assembly instructions of the pump manufacturer!

- 1 Place motor and pump horizontally and level (fig. 9).
- 2 Turn motor shaft by hand before assembly. It must turn freely after overcoming the adhesive friction.
- 3 Apply acid-free, waterproof grease to the coupling internal toothing.
- 4 Remove hexagon nuts from the studs of the motor.
- 5 Align the pump so that its cable guard is in line with the lead exit of the motor and guide pump and motor together.
- 6 Place spring rings on the studs and tighten the nuts crosswise.

Strictly observe the tightening torques of the unit manufacturer.



Attention

Check radial and axial clearance of the motor shaft. There must be no rigid connection since otherwise motor and pump will be damaged during commissioning.

- 7 Protect coupling spot against contact.

8 Electrical connection

Please observe the specifications on both the nameplate and the enclosed data sheet. The following connection examples refer only to the motor itself. They are no recommendation regarding the control elements connected upstream.

8.1 Fusing and motor protection

- 1 Allow for an external mains switch 1 (fig. 10) in order to be able to switch the system dead at any time.
- 2 Allow for fuses for each individual phase (fig. 11)
- 3 Allow for a motor overload protection in the switchbox (fig. 12)
 - Warranty is void without thermal protection
 - Motor protection according to EN 60947-4-1
 - Trip time at 500% $I_N < 10$ sec. (cold bi-metal)
 - overload setting at operation current (max. I_N)
- 4 Allow for an emergency stop.



8.2 Earthing

Consider motor power rating when dimensioning the earth connection in accordance with IEC 364-5-54 and EN 60034-1.

- Motor has to be earthed.
- Provide good contact of the protective conductor terminal.

8.3 Lightning protection

Various models already feature a over-voltage protection ex-works. For all other models please consult Franklin Electric.

8.4 Connecting examples

- 1 3-phase connection (fig. 13). Connect motor so that its direction of rotation corresponds to that of the unit. The connection features the usual circuit with a clockwise rotating field and an counter clockwise rotation for the motor shaft.
- 2 Super Stainless 2-wire connection (fig. 14)
- 3 Super Stainless 3-wire connection (fig. 15)
- 4 Super Stainless PSC (Fig.: 16)

8.5 Operation with a soft starting device

- Adjust soft starter to 55% of the rated voltage
- Adjust acceleration and deceleration time to max. 3 seconds.
- Soft starting device has to be bridged after acceleration with a contactor.
- Please strictly observe the manufacturer's operating instructions.

8.6 Operation with variable frequency drives

For operation with variable frequency drives please consult Franklin Electric.

9 Work on the motor



Attention

De-energize system to the beginning of the work and protect it against unintended re-energizing (fig. 17).

Regarding the trouble shooting and rectification on the entire system please strictly observe the appropriate instructions of the motor and unit manufacturer.

Never open the motor since it can only be shut and adjusted with special tools.

Do not carry out any modifications or conversions to the motor or its electrical connections.

After completion of the work apply all safety and protective devices completely and check for their function.

9.1 Checking/ replenishing the motor filling

If your motor is older than 1 year (see date code), the filling level of the motor fluid has to be checked prior to installation.

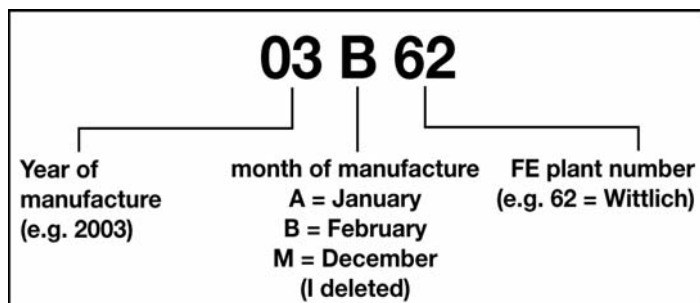

For motors with 1500 N / 3000 N / 4000 N axial load

- 1 Clamp motor in a vertical position, shaft down, but never resting on the shaft end (fig. 18).
- 2 Undo the three slotted screws of the diaphragm cover and take it off. Remove the diaphragm.
- 3 The motor is to be filled up to the half of the diaphragm receptacle. If this is not the case, refill it with clean drinking water or Franklin Electric original filling FES93 (308 353 941) (fig. 19).

For High Thrust motors with 6500 N axial load

For this purpose, you need the Franklin Electric Filling Kit (308 726 103).

- 1 Place motor horizontally.
- 2 Guide test pin very carefully through the bore in the diaphragm cap until a slight resistance can be felt (fig. 20).
- 3 Filling level is sufficient if notch A on the test gauge is still visible (diaphragm level 10 mm +/- 2 mm) (fig. 20).

If the filling level is not sufficient, proceed as follows:

- 1 Carefully place motor vertically on the membrane cap.
- 2 Carefully force filter cover and filter out of the endbell.
- 3 Press test gauge very carefully into the underlying valve in order to vent the motor.
- 4 Place filling syringe on the valve and inject motor fluid FES93 (308 353 941) until the optimum filling level is reached.
- 5 Check filling level with horizontal motor, as already described.

Attention



Replenish missing motor fluid either with clean drinking water or, in order to ensure frost protection, with Franklin Electric filling liquid, item no.: 308 353 941.

- 6 In the case of over-filling, carefully press test gauge into the valve and drain off some filling liquid.

9.2 Measuring the insulation resistance

Perform this measurement before and while the assembled unit is **powered** to the place of application.

The motor is ok if the insulation resistance at 20 °C is at least:

Minimum insulation resistance **with extension cable**:

- for a **new** motor > 2 MΩ
- for a **used** motor > 0,5 MΩ

Minimum insulation resistance **without extension cable**:

- for a **new** motor > 200 MΩ
- for a **used** motor > 200 MΩ

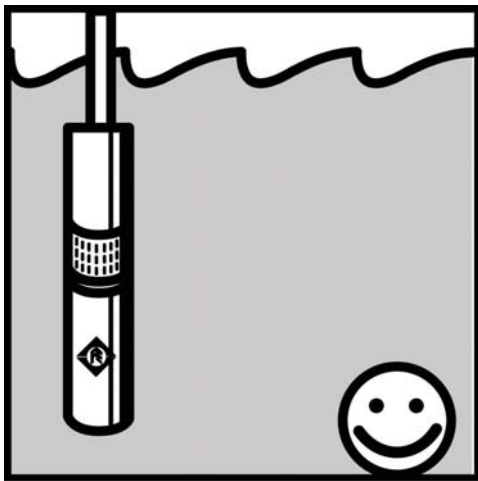

Fig.: 1

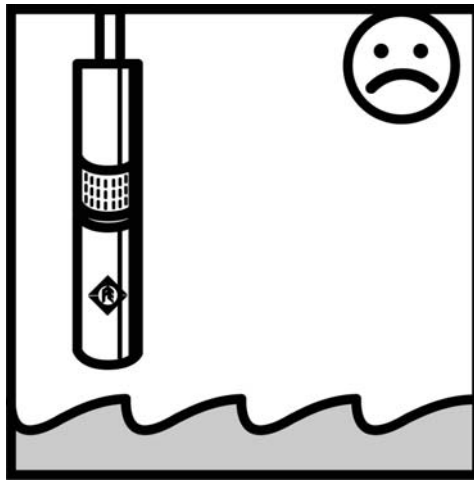

Fig.: 2

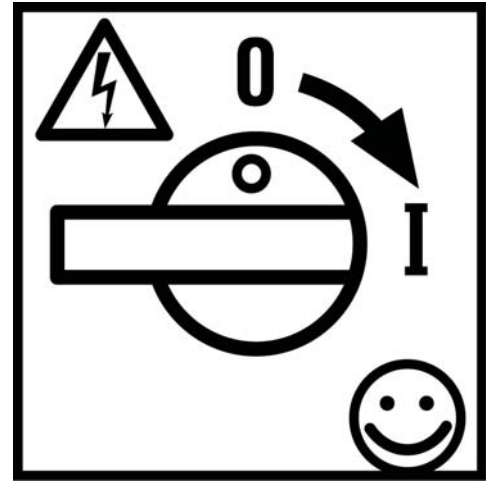

Fig.: 3

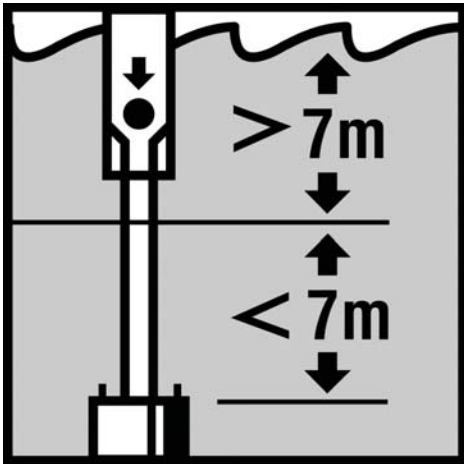

Fig.: 4

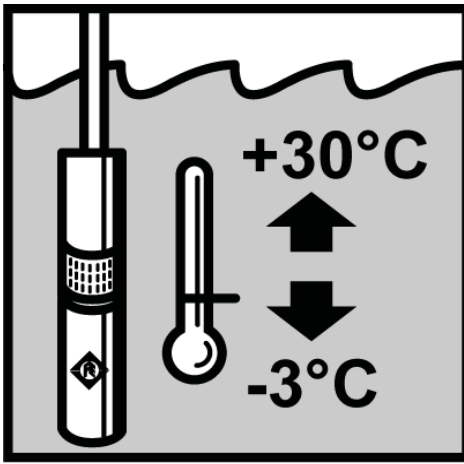

Fig.: 5

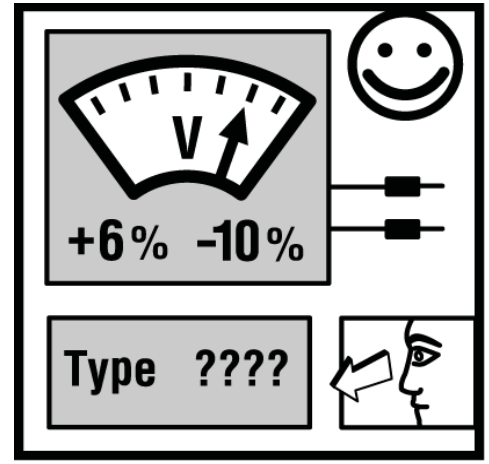

Fig.: 6

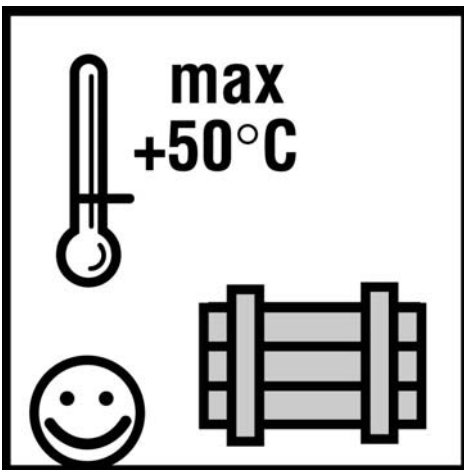

Fig.: 7

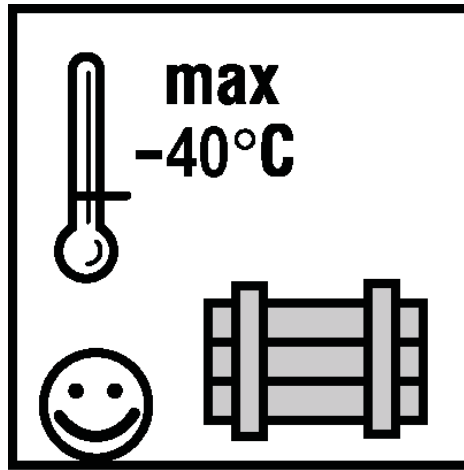

Fig.: 8

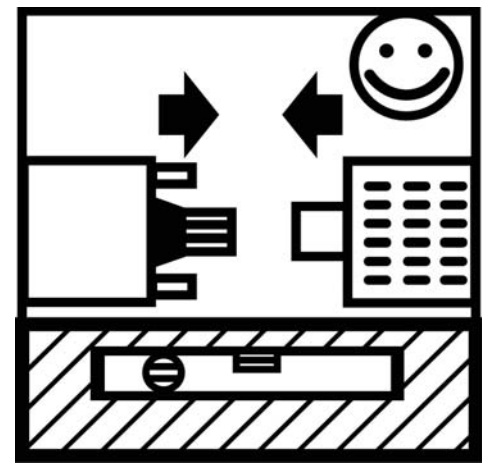

Fig.: 9

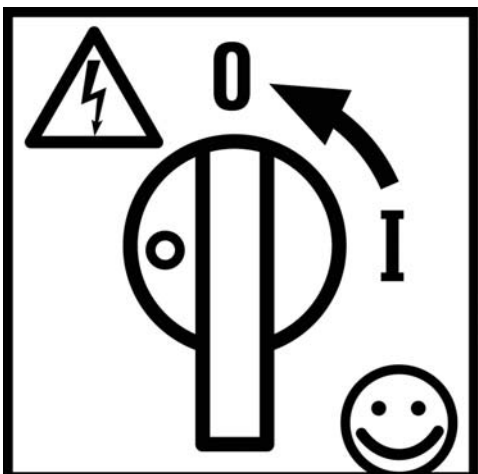

Fig.: 10

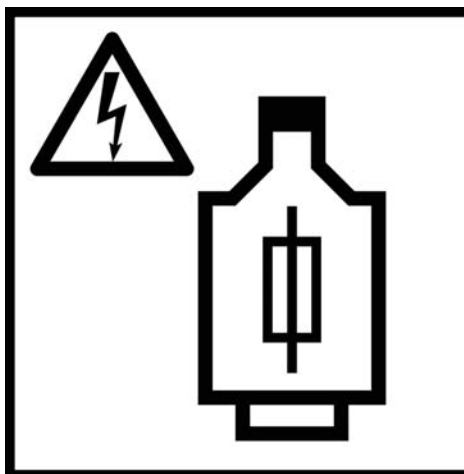

Fig.: 11

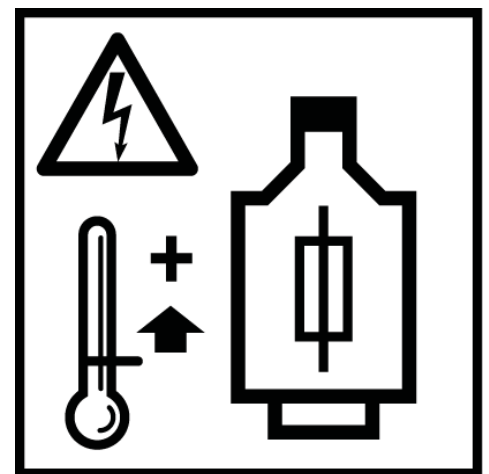

Fig.: 12

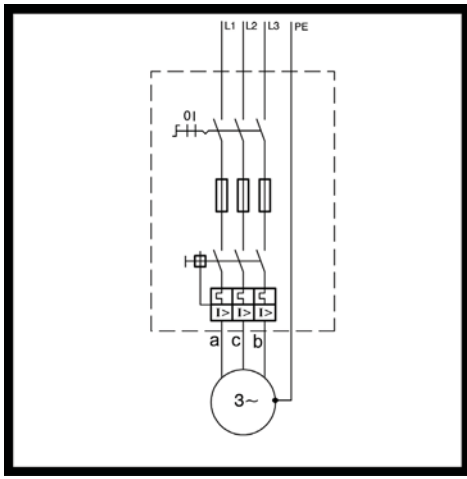

Fig.: 13

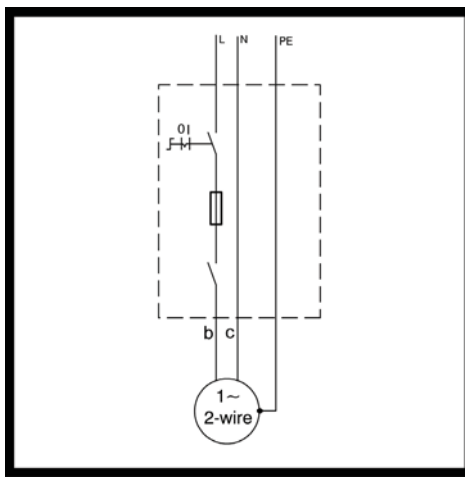

Fig.: 14

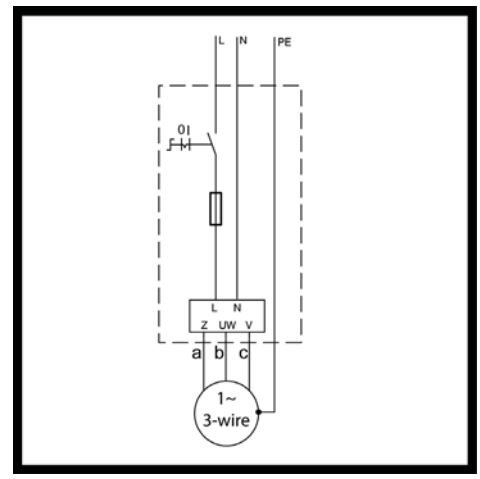

Fig.: 15

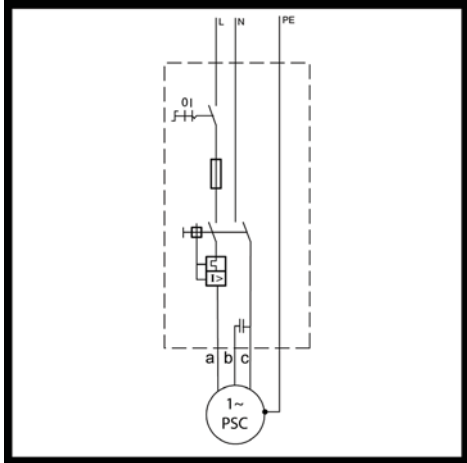

Fig.: 16

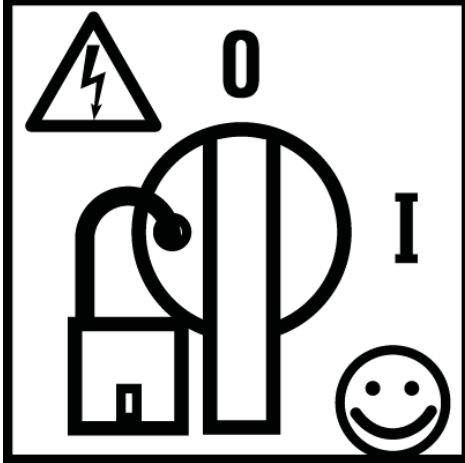

Fig.: 17

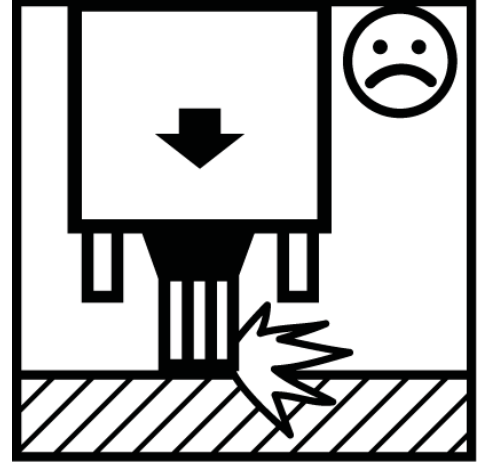

Fig.: 18



Fig.: 19

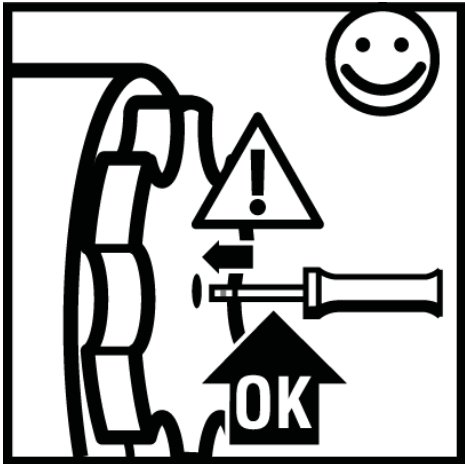

Fig.: 20

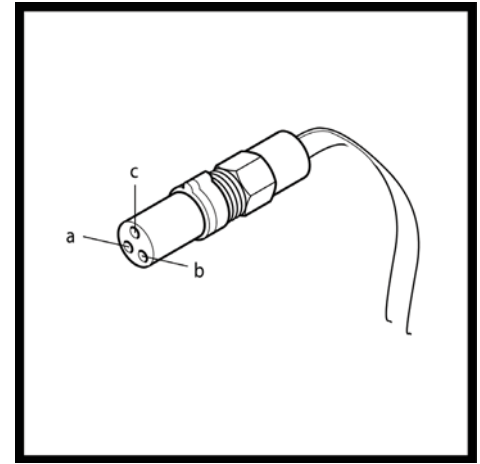

Fig.: 21

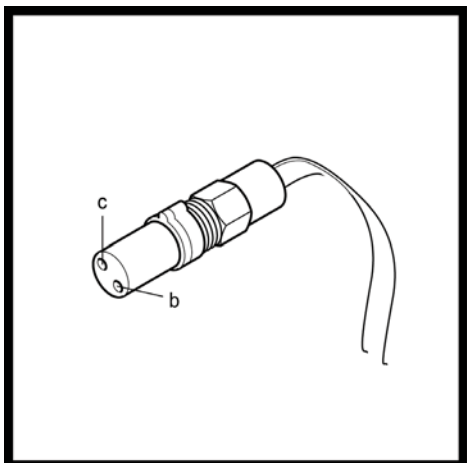

Fig.: 22

	a	b	c
(GB)	black	brown	grey (blue)
(D)	schwarz	braun	grau (blau)
(F)	noir	marron	gris (bleu)
(I)	nero	marrone	grigio (blu)
(E)	negro	café	gris (azul)
(P)	preto	castanho	cinza (azul)

Fig.: 23