

DELTA

HORIZONTAL, SINGLE STAGE, END SUCTION
CENTRIFUGAL PUMP

SSA

INSTRUCTION FOR INSTALATION,
OPERATION & MAINTENANCE

PUMP TYPE	: SSA..... --
PUMP SERIAL No	:
CAPACITY	:m ³ /h
HEAD	:m
SPEED	:RPM
POWER	:HP

Contents	Page
A - General	1
A1 - Handling	1
B1 - Installation	1
B2 - Aligning the coupling	1
B3 - Connecting the piping	2
C - Start up shutdown	3
C1 - Preparations	3
C2 - Start up	3
C3 - Shutdown the pump	3
D - Maintenance and Lubrications	3
D2 - Lubrication and grease change	3
E - Dismantling repair and reassembly	4
E1 - Preparations	4
E2 - Reassembly the pump	4
E3 - Shaft seal	4
F - Spare parts	4
G - Faults and causes	5

A - GENERAL

- A centrifugal pump operates very many years satisfactorily and trouble - free if it is correctly chosen and properly installed and maintained.
- Follow the instruction in this manual carefully if you wish to operate your pump trouble - free.
- Do not run the pump under any other operating condition different then those given to us by order.
- This manual does not take into account any site safety regulation which may apply.
- The pump type, serial numbers, date of production and main operating data are indicated on the pump nameplate. Please state this information when consulting us for any kind of question or problem and in particular when ordering spare parts.

A1 - HANDLING

When handling the complete pumpunit suspend the unit as shown in Fig.1. (Especially do not use the motor eyebolt for carrying the complete unit.)

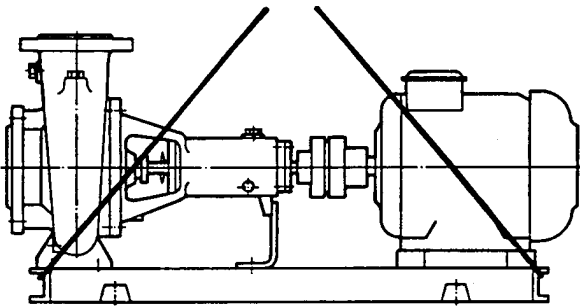

Fig.1 : Pump and motor on a common baseplate

B- INSTALLATION

B1 Installation (on site)

- B1.1-** Make sure the concrete foundation has set firm and solid before mounting the pumpset. The surface of the foundation should be truly horizontal and perfectly flat.
- B1.2-** Place the pumpunit on the concrete foundation and align by using a spirit level on the discharge flange. Make sure it is completely horizontal by using shims as shown on Fig.2.
- B1.3-** Slightly tighten the anchor bolts.
- B1.4-** Check the coupling alignment as explained in B2.
- B1.5-** Fill in the baseplate with concrete. Make sure there is no air left in it and the baseplate is well integrated with concrete foundation.
- B1.6-** Wait until the concrete firmly set. (Minimum 3 days)
- B1.7-** Tighten the anchor bolts. Check the coupling alignment again.

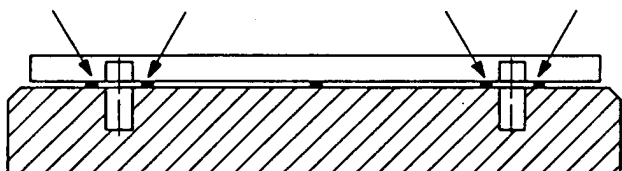

Fig.2: Foundation, baseplate and fitting the shims.

B2- ALIGNING THE COUPLING

For a trouble free service life of the pumping unit the most important factor is aligning the couplings properly. The main reason for vibration, noise, warming bearings and overloading is an unaligned coupling. Therefore the coupling should be correctly aligned and be checked frequently.

Flexible coupling do not correct the false axial centering. But it only enables centering errors to be seen. Coupling misalignment must be corrected.

B2.1- "Coupling Alignment" means to secure the motor and pump rotation axis on the same straight line. **SSA** series pumps are dispatched from our factory after the coupling alignment is precisely secured. The alignment has to be checked at site after transportation, mounting and installation are beaing carried out be sure in precise.

B2.2- Two pieces of minimum 100 mm. long metal stripes with straight edge (Steel ruler) and a precise calliper are needed to align the coupling. (Special instruments must be used for a very fine and precise alignment.)

B2.3- There may be two types of errors for the coupling alingment.

- Parallel sliding error (Misalignment)
- Angle error.

B2.4- To control parallel sliding error, straigh edged steel ruler is pressed down on one half of the coupling in parallel to the axis. It is checked against the other half. Straight edge must touch to the both half couplings completely same at all points. The same operation should be done reciprocally in two points in each vertical and horizontal planes.

B2.5- To check the angle error, the gap between the two coupling halves must be the same at all four points horizontally and vertically.

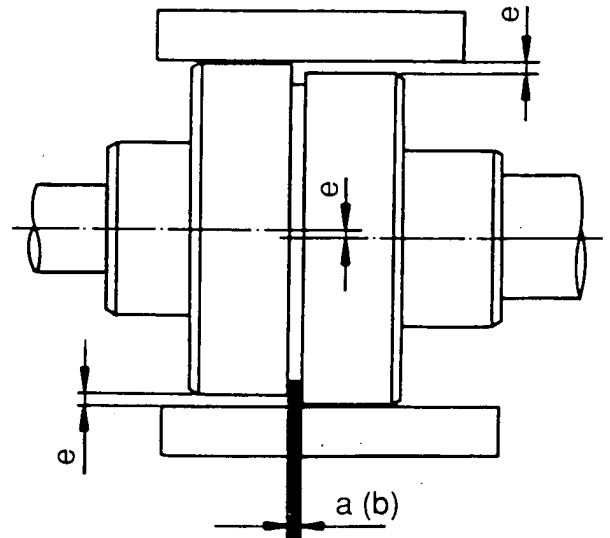

Fig.3- Aligning a flexible coupling

B2.6- Alignment errors can be either on vertical plane or horizontal plane. On vertical plane alignment is corrected by inserting shims under the pump or motor foot, and on horizontal plane alignment is corrected by sliding the pump or motor horizontally sideways by using the gaps at mounting holes.

Fig.3a, 3b, 3c, 3d show the alignment of coupling step by step.

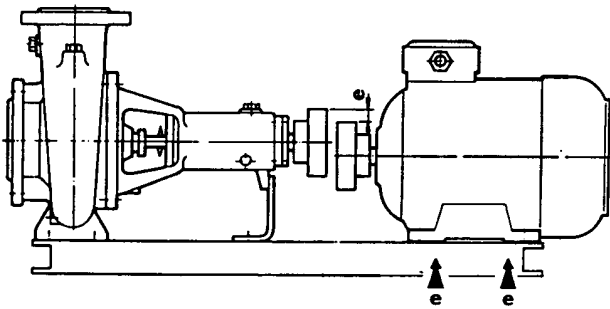

Fig.3a- Parallel sliding error in vertical plane and to settle.

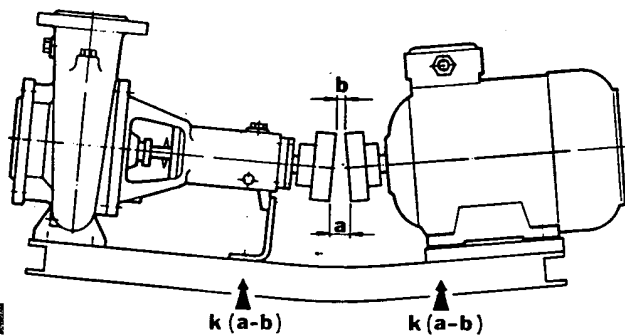

Fig.3b- Angle error in vertical plane and to settle.

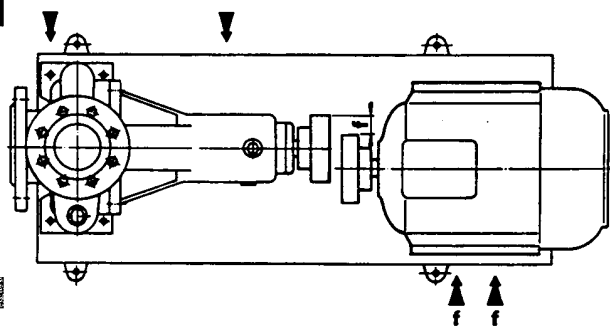

Fig.3c- Parallel sliding error in horizontal plane and to settle.

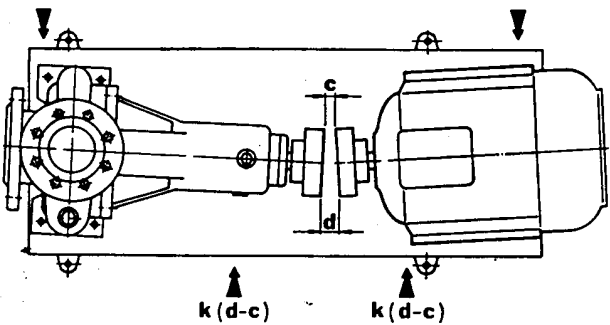

Fig.3d- Angle error in horizontal plane and to settle.

B3- CONNECTING THE PIPING

B3.1- Never use the pump as an anchorage point or as a carrier for the piping.

B3.2- Suction lift lines should be run with a rising slope toward the pump.

B3.3- The pipes should be supported very near the pump. It must be checked that any weight, stress or strains on the piping system should not be transmitted to the pump.

Therefore after completing the piping installation, the bolts and connections on the suction and discharge ports must be loosened to ensure that there is not any stress on the piping system to the pump.

B3.4- The nominal bores of the pipes should be same as or greater than those of the pump nozzles. Never use pipes or accessories which have smaller bores than the pump nozzles.

Particularly foot valves, strainers, filters and non return valves must be preferred with larger free transition areas.

B3.5- Thermal expansion of the pipework should be accommodated by suitable means so as not impose any extra load on the pump.

B3.6- Prevent impurities such as welding beads, scale, sand and tow might be left in the pipes while production of the piping system harms the pump. Seal the pump nozzles by means of blind gasket to stop impurities get in the pump. After assembling the system all the piping parts must be disassembled, thoroughly cleaned, painted and reassembled again. If a strainer is used on the suction side of the pump, it must be cleaned after several days of operation.

B3.7- Install the auxiliary pipe connections for cooling water, drainage etc. necessary for the pumping system.

B3.8- Minimum flow : If there is a possibility of the pump having to operate at zero flow (against a closed discharge valve), then a minimum flow valve (or a by - pass check - valve) must be installed on the discharge nozzle. In cases where there is no such a valve operating, the pump against close valve for a long time causes considerable damage on the pump.

B3.9- Final Check : After completion all the above process check the coupling alignment as described in **B2**. Correct if there is a fault. Rotate the pump rotor several times by hand. Make sure rotor rotates easily.

B3.10- Fix the coupling guard back in the place where it was removed before or check the coupling alignment. Do not operate the pump before doing so. This is a necessity for security and job safety.

C - START UP SHUTDOWN

C1- Preparations :

C1.1- Lubrication control : Grease lubricated bearings are factory packed with grease enough for one year operation before dispatch. If the pump is stored for a long time before installation (more than 6 months) pump extra grease on bearings. Oil lubricated pumps are dispatched without oil and this is indicated with a warning label. Fill the bushings of this kind of pumps with oil until the marked level on the gauge. (see D2 for lubricating.)

C1.2- Check the shaft seal. (See E3)

C1.3- Make sure that the pump and suction pipes are completely filled up with water. There is no problem for the pumps which have positive suction head. If there is a valve on suction line, it must be opened and air taps are loosened to enable the water replaces air in the pump, until it is completely full with water.

If there is a foot valve for the pumps which has suction lift, pump is filled up with water through the filling tap at the highest point of the pump and the air is emptied out.

If the system has a vacuum pump, water is brought up in the rising pipe and filled up the pump through this vacuum pump. When water is risen up to the highest point then the pump is started up. This problem is solved within the system itself on self priming pumps.

WARNING : Make sure the pump never runs dry.

C1.4- Checking the direction of rotation : **SSA** type pumps rotate in clockwise when it is looked from coupling to the pump. This direction is already indicated on the pump nameplate by an arrow. Check this by switching the pump on, then off again immediately. Fit the coupling guard if you took it out.

C2. START UP

C2.1- Check if the shut off valve in the suction valve is open and the shut off valve in the discharge line is closed.

C2.2- Switch on the circuit breaker and run the motor.

C2.3- Wait until the motor reaches the full speed, (on star-delta running motors wait until it switches on delta).

C2.4- Open the discharge valve slowly while watching the ampermeter on the control panel. (If the discharge line is empty do not turn on the valve fully open on first start up. Turn it on slowly to maintain the value on the ampermeter is under the rated current value of the motor.)

C2.5- When the valve is if fully open, check the pressure on the manometer and see it is the same with the duty point pressure. If the pressure on the manometer is lower than duty point pressure bring them to the duty point value by slightly closing the valve. If it is higher value, check your installation, particularly the static head again.

C3. SHUTDOWN THE PUMP

C3.1- Slowly close the shut - off valve in the discharge line

C3.2- You may shut down the pump without closing the shut-off valve if there is a device for water hammer protection on the discharge line or the water hammer is not a considerable level.

C3.3- Switch off the driver. Ensure the pump set runs down smoothly and quietly to a standstill.

C3.4- If the set is to remain out of services for a long time close the shut-off valve in the suction pipe. Close off the auxiliary connections. In the event of frost and / or prolonged standstill, drain the pump or otherwise protect against freezing.

D- MAINTENANCE AND LUBRICATION

D1 - Supervision of operation

D1.1- The pump must run smoothly, quietly and free from vibration at all times.

D1.2- The pump must never run dry.

D1.3- Never run the pump for a long period against a closed discharge valve. (At zero flow)

D1.4- The bearing temperature may exceed the ambient temperature by up to 50°C. But must never rise above 80°C

D1.5- The valves in the auxiliary lines must remain open while the pump is running.

D1.6- If the pump has a soft packing type stuffing box, this should drip during operation. The gland nuts should only be lightly tightened.

D1.7- If leakage becomes excessive after a long period of operation, uniformly tighten the gland nuts by 1/6 th of a turn. If the gland nuts can not be tightened any further insert an extra packing ring.

D1.8- If the pump has a mechanical seal, this will experience only minor leakage or no visible leakage during operation. It is maintenance free. If there is considerable leakage from the seal, that means the seal surfaces are worn - out and it needs to be replaced.

D1.9- Stand - by pumps should be run for a short time at least once a week, to ensure they are in constant readiness for operation. Check the integrity of the auxiliary connections.

D1.10- The flexible coupling elements should be regularly checked and replaced as soon as they are shown signs of wear.

D2- LUBRICATION AND GREASE CHANGE

D2.1- The bearings of SSA series of pumps normally is closed type with life grease lubricate. Types required to be lubricated by oil are produced in special request

D2.2- Periods of changing oil :

For SSA Type pumps (2800 RPM) : 1500 operating hours
For SSA Type pumps (1450 RPM) : 3000 operating hours.
The oil has to be changed at the end of those periods.

D2.3- Please use high quality suitable oil for lubrication. For example :

SHELL TELLUS 46 cSt (2800 RPM)
SHELL TELLUS 68 cSt (1450 RPM)

D2.4- See the attached table for required amount of oil according to pump types.

D2.5- Check the oil levels on oil lubricated bearings frequently, fill up when shortened. Empty the old oil, clean the box and refill with new oil until the indicated level on the gauge once a year maximum.

Pump Dimension Group	Shaft end Diameter	Ball Bearing Type Nubmer	Oil fill
A1 -A2-A3-A4	24	2 x 6306	0.35 lt
B1-B2-B3-B4	32	2 x 6308	0.65 lt
C1-C2	42	2 x 6310	1.10 lt
C3	42	2 x 6310	1.30 lt
C4	55	2 x 6312	1.80 lt

TABLE - 1 Ball Bearings / Lubricant Fill

E - DISMANTLING REPAIR AND REASSEMBLY

E1- Preparations :

WARNING : Before starting work on the pumpset, make sure it is disconnected from the mains and can not be switched on accidentally.

E1.1- Close all valves in the suction and discharge lines, take off all the plugs and drain the pump.

E1.2- Detach pump suction and discharge flanges and all auxiliary supply lines, disconnect the pump from the piping system. No need for this operation for the pumps where SPACER TYPE coupling is being used. (Back pull out design). For this application pump rotor assembly can be pulled out without dismantling the volute casing.

E1.3- Remove coupling guide.

E1.4- Disconnect pump from the driver and detach from the besaplate. (No need to dismantle the motor for the pumps which have spacer types of couplings). Unscrew the bolts which mount bearing housing to the volute. Take out spacer part of coupling from where is mounted. Use the space available to pull out Bearing housing and rotor assembly.

E1.5- Pull off the coupling from the shaft using a pull-off device and remove key. You may also use a rust remover solvent.

E1.6- Mark each part to be taken out before dismantling the pump. Mark the places where they have to be reciprocated

E1.7- Unscrew the bolts which is mounting bearing housing to the volute casing and pull out bearing and rotor assembly. (this process was explained before for pumps with spacer type of couplings). Unscrew the end nut of impeller and take out the impeller. Use rust remover solvent if necessary during dismantling. Dismantle bearing covers, stuffing box, shaft and ball bearings.

E1.8- Clean all the parts, replace damaged or worn-out ones.

E2- REASSEMBLY THE PUMP

E2.1- Reassemble in accordance with standard engineering practice. You may find the attached drawings useful.

E2.2- Coat the seats and screw connections with graphite, silicon or similar slippery substance before reassembly. If you can not find any of the above you may use oil instead (accept the pumps for drinking water)

E2.3- Never use the old gaskets, make sure the new gaskets and o-rings are the same size as the old ones.

E2.4- Start mounting from the bearings. Place ball bearings on their places on the shaft by slightly heating or by using press. Put this part to the bearing housing from the coupling side. Put the bearing covers at both ends to their places. Place stuffing box and impeller and tighten the impeller nut.

E2.5- Mount rotor assembly to volute casing.

E2.6- Make sure the gaskets and o - rings are evenly placed without sliding and not damaged or not squeezed at all.

E2.7- Place the pump on the baseplate, couple the motor. Connect suction and discharge pipes as well as auxiliary pipes. Take the unit into operation as it was indicated in item A.

E3- SHAFT SEAL

E3.1- While starting to change soft packing throughly clean the stuffing box and shaft sleeve.

E3.2- Cut enough number of pieces at the suitable length diagonally from suitable size of soft packing. Roll it up over the shaft sleeve and see the ends are in full contact.

E3.3- Insert the first packing ring as the joint will place up, and press home using the gland cover.

E3.4- Place the second ring as joint will place down. Insert all the packing rings in the same way. If there is a lantern ring put it into place too.

E3.5- Place the gland and fully tighten, thus the packing rings will take the shape of stuffing box, then loosen it. Slightly tighten by turning the shaft and stop tightening when it slightly brakes the shaft.

E3.6- After starting operation, it is necessary that water drips from the packing. This dripping shouldn't be less than 10 cm³/min and more than 20 cm³/min. Adjust dripping by uniformly tightening and slacking the gland nuts slightly.

E3.7- Check the temperature of soft packing after two hours operation after gland adjustment to avoid overheating. Packing temperature must not exceed 80°C where pumping liquid temperature is the same as ambient temperature.

E3.8- Follow the instructions of mechanical seal manufacturers for the pumps having mechanical seals.

F-SPARE PARTS

F1- DELTA PUMPS guarantees to supply the spare parts for **SSA** type pumps for 10 years. You can provide any spare part easily.

F2- Let us know the following details on the name-plate, when you order spare parts.

Pump Type and size : (SSA 125 - 315)

Motor power and speed : (40 HP - 1450 R.P.M.)

Prod. Year and Serial Number : (1992 - 13 987)

Flow and Man. Head : (200 m³/h - 30 m.)

F3- If you prefer to have spare parts in your stock, we recommended you to have the following quantities for a two years operation depending on the number of same type of pumps

Part No	Part name	Number of pumps in the system						
		2	3	4	5	6,7	8,9	10 +
60	Shaft (Incl. keys)	1	1	2	2	2	3	30%
50	Impeller	1	1	1	2	2	3	30%
20	Wear rings (if any)	2	2	2	4	4	6	50%
200	Ball bearings	2	2	4	4	6	8	50%
30	Bearing housing	-	-	-	-	-	1	2
420	O-Rings for casing	4	6	8	8	9	12	150%
400	Soft packing (set)	4	4	6	6	6	8	40%
70	Shaft sleeves	1	1	1	3	2	2	20%

SSA TYPE PUMPS - DIMENSION GROUPS
(Pump dimensions conforming with DIN - 24255)

G- FAULTS and CAUSES

In this section you will find faults at operations and their reasons for **SSA** pumps.

1- Pump doesn't deliver any water after start - up.

- a) There may be air existing in pump or suction pipe.
- b) Too much suction manometric head.
- c) Insufficient manometric head.
- d) Reverse rotation.
- e) Speed too low.
- f) Impeller or check - valve is clogged.

2- Flow is going down or no flow at all.

- a) Ingress of air through shaft seal, suction pipe or suction port. Pump lifts the water with air.
- b) Air pocket in the suction pipe.
- c) Increase at total manometric head.
- d) Impeller or strainer clogged partially.

3- Driver overloaded.

- a) Pump is operating at lower manometric head.
- b) Speed is too high.
- c) Mechanical frictions inside the pump.
- d) Excess tightened soft packings.
- e) Bad coupling alignment.

4- Bearings overheating.

- a) Bad coupling alignment
- b) Insufficient lubrication, deterioration into oil or no oil.
- c) Bearing covers are too tight.
- d) Insufficient cooling.
- e) Existence of excess grease.

5- Vibration on pump.

- a) Bad coupling alignment.
- b) Unbalanced rotating parts.
- c) Partially clogged impeller.
- d) Worn - out and defected impeller.
- e) Oblique shaft.

6- Noise level is high.

- a) Flow rate is too high or too low. Pump runs out of duty range.
- b) There is air in water.
- c) Pump is working at cavitation conditions.

Pump Type	Dimension Group	Characteristic Dimensions Shaft Diameter / F-Lenght			
32 - 125 40 - 125 50 - 125 65 - 125	A1	24 / 360			
32 - 160 40 - 160 50 - 160 65 - 160 80 - 160	A2				
32 - 200 40 - 200 50 - 200 65 - 200	A3				
40 - 250 50 - 250	A4				
100 - 160 50 - 315	B1		32 / 470		
80 - 200 100 - 200 125 - 200	B2				
65 - 250 80 - 250 100 - 250 125 - 250 150 - 250	B3				
65 - 315 80 - 315 100 - 315	B4				
125 - 315 150 - 315	C1			42 / 530	
80 - 400 100 - 400 125 - 400 150 - 400	C2				
200 - 260 200 - 315	C3				42 / 630 42 / 610
200 - 400	C4				55 / 675

SECTIONAL DRAWING

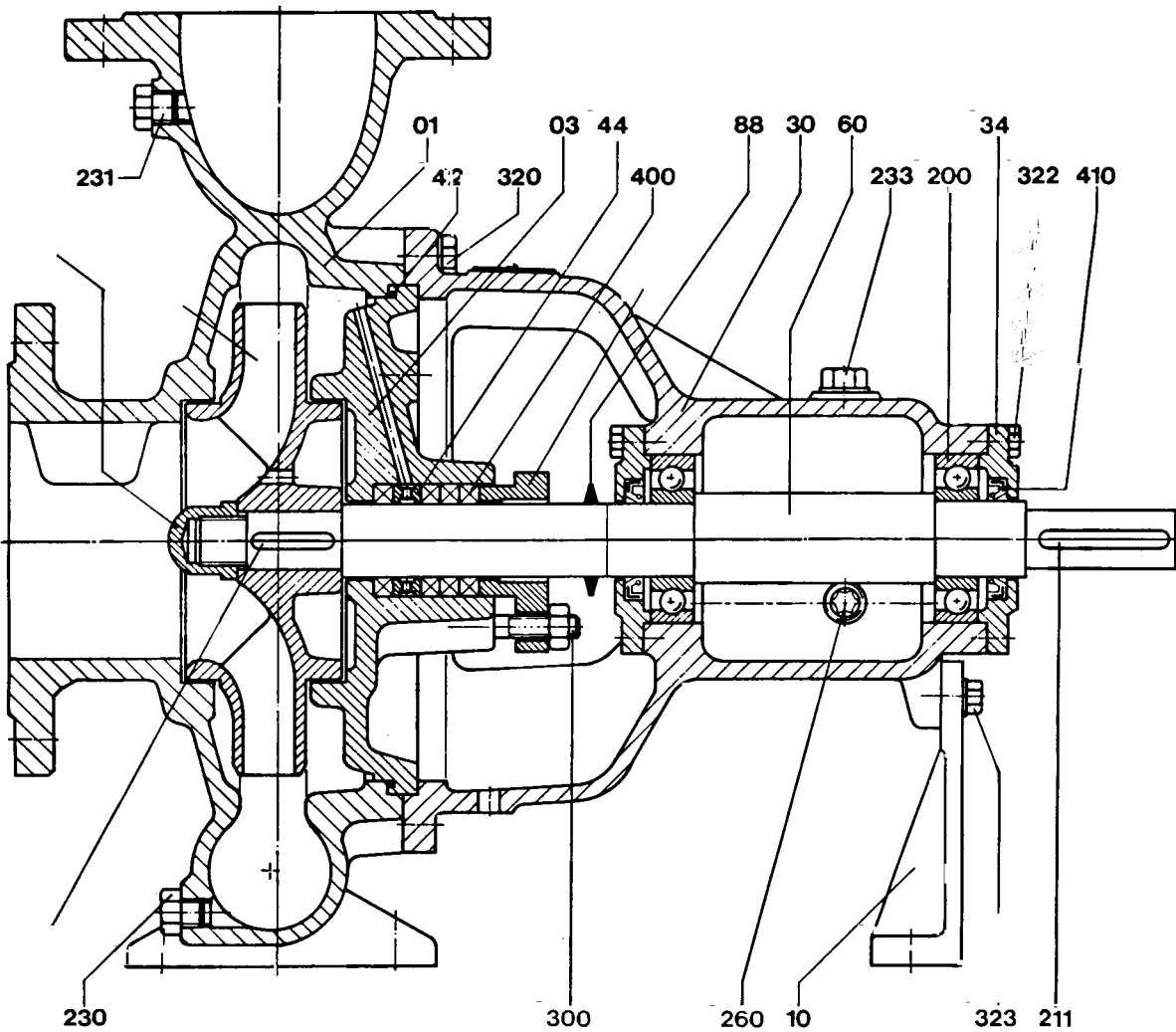

PARTS LIST

- | | |
|--------------------------------------|-------------------------------|
| 01— Volute casing | 200— Ball bearing |
| 03— Stuffing box cover | 210— Impeller key |
| 10— Frame foot | 211— Coupling key |
| 20— Case wearing ring | 230— Air plug |
| 30— Bearing housing | 231— Drain plug |
| 34— Bearing cover (oil lub.) | 232— Oil drain plug |
| 35— Bearing cover (grease lub.) | 233— Oil filling plug |
| 41— Stuffing box with cooling jacket | 240— Seal tubing |
| 42— Stuffing box gland | 260— Oil eye |
| 44— Lantern ring | 261— Grease fitting |
| 46— Mech. seal box-type. 1 | 300— Gland stud and nut |
| 47— Mech. seal box-type. 2 | 320— H.Cap screw (casing) |
| 48— Mech. seal housing | 322— H.Cap screw (Bea. Cover) |
| 49— Mech. seal cover | 323— H.Cap screw (frame foot) |
| 50— Impeller | 400— Stuffing box packing |
| 60— Pump shaft | 410— Oil seal |
| 65— Impeller nut | 420— O-ring (Casing) |
| 70— Shaft sleeve | |
| 88— Deflector | |

