

Technical data sheet

Type 302P

Foot valve
System 02

Applications and special features



- Operates in any position from horizontal to vertical ascending
- Minimum head loss
- Silent, reliable sealing, compact
- Exceptional robustness
- Does not generate hammering
- Closing system : long back axial guiding for reduced displacement
- Sealing guaranteed by a flat seal
- Return spring

Technical description

DN "	PN mm	PFA in bar	PS in bar				Cat.	References	Vvs-nr	
			L1	L2	G1	G2				
2	50	10/16	16	16	16	x	x	3.3	149B 2746	
2 ^{1/2}	65	10/16	16	16	16	x	x	3.3	149B 2747	
3	80	10/16	16	16	16	x	x	3.3	149B 2748	
4	100	10/16	16	16	16	x	x	3.3	149B 2749	

Important notice:

The indicated pressure for the different categories of fluids (L1/L2/G1/G2) is under no condition a guarantee of use. Therefore, it is essential to validate the use of products under given operating conditions. In order to facilitate your choice regarding these new regulatory requirements, Danfoss Socla has put the necessary information concerning products with CE marking, specification sheets and product identification plates at your disposal in the price list (+ see additional explanations on the detachable slip). In addition, the operating instructions are available on our web site www.danfoss-socla.com or by requesting from our sales department.

- **Connection** : flanges drilled PN : see table
- **Permissible operating pressure PFA - water-** (for supply, distribution and disposal of water) : See table
- **Maximum permissible pressure PS - other mediums :**
See table
- **T° :**
Mini. -10 °C
Maxi. 80 °C
- **Mediums** : Clear liquids
- **Approvals** : VERITAS (France), ACS (France)
- **International construction Standards** :
CE Conformity Directive 97/23/CE
Flange drilling according to EN1092-2

Overall dimensions

DN		B	C	D	Weight
"	mm	mm	mm	mm	kg
2	50	171	165	97	4,2
2 ^{1/2}	65	212	185	125	6,2
3	80	257	200	150	9
4	100	313	220	181	13,2

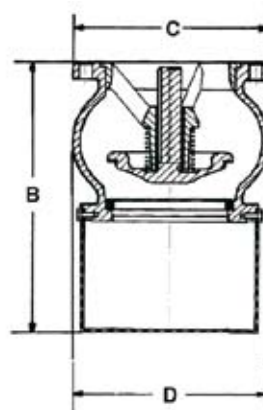

Technical data sheet Type 302P - Foot valve

Spare parts list and materials

Nb	Description	Materials	EURO	ANSI
1	CASING	Cast iron + epoxy	EN-GJL-250	ASTM A 48 35 B
2	RING	Bronze	CuSn12-C	
3	GUIDE DN50	Bronze	CuSn5Zn5Pb5-C	ASTM B 505
	DN65 to 100	Cast iron + epoxy	EN-GJL-250	ASTM A 48 35 B
4	SPRING	Stainless steel	X10CrNi18-8	AISI 302
5	SEAL	EPDM		
6	CLOSING SYSTEM DN80-100	Cast iron + epoxy	EN-GJL-250	ASTM A 48 35 B
	DN50-65 : one-piece	Bronze	CuSn5Zn5Pb5-C	ASTM B 505
7	STEM	Bronze	CuSn5Zn5Pb5-C	ASTM B 505
8	SCREW	Galvanised steel		
9	STRAINER	PP (Polypropylen)		

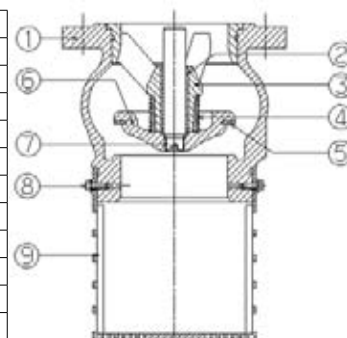

Working principle

DN	Opening pressure in mm/CE	Kv	ζ
2	230	89,00	1,23
2 ^{1/2}	240	143,00	1,36
3	280	199,00	1,60
4	290	356,00	1,20

Directions for use :

- Solid line : Valve completely open
- Dotted line : opening stage of valve

ΔP

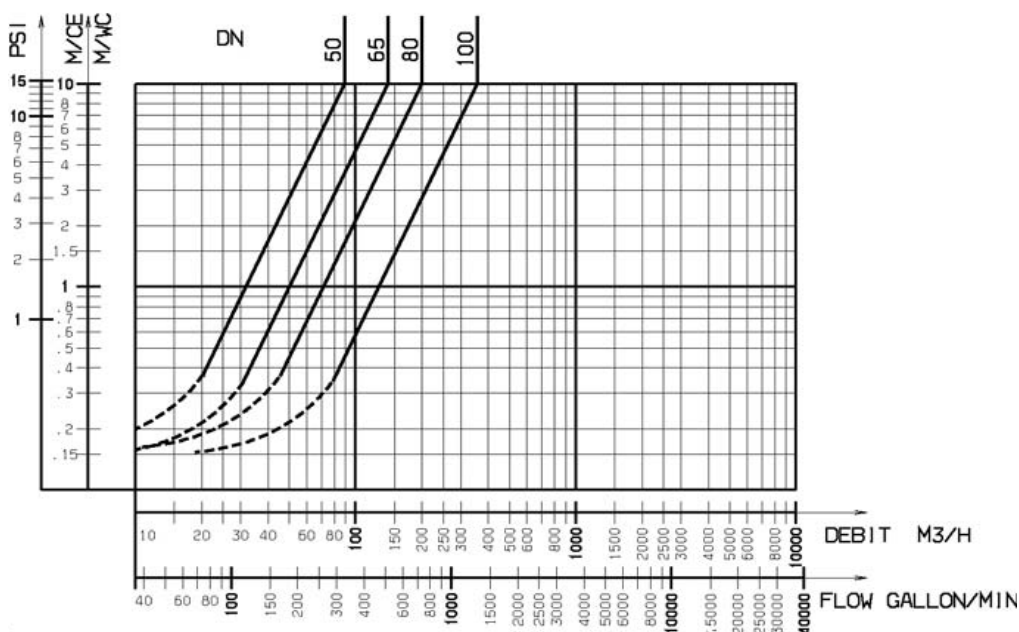

Danfoss can accept no responsibility for possible errors in catalogue, brochures and other printed material. Danfoss reserve the right to alter its products without notice. This also applies to products already agreed. All trademarks in this material are the property of the respective companies. Danfoss and the logo type are trademarks of Danfoss A/S. All right reserved.