

Fixed installation with 1 Drenag 1800 T pump, complete with ED 2,5 T control unit, with one MIN/MAX level control float and 1 alarm float.

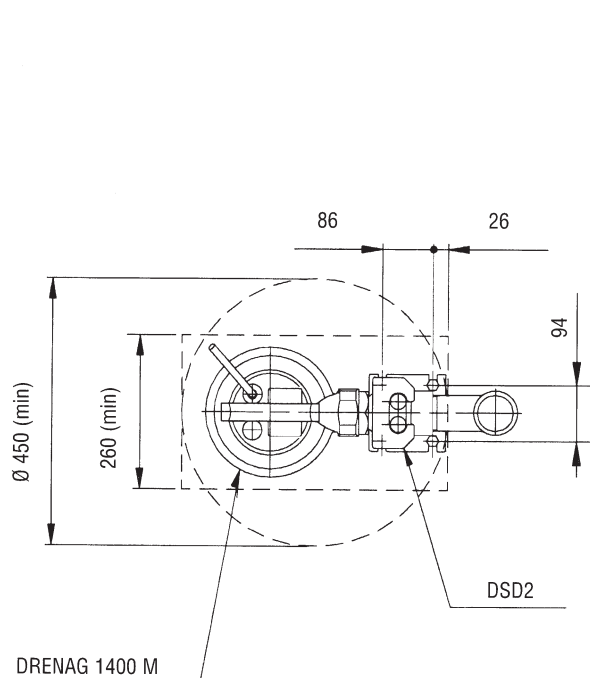

Minimum dimensions of borehole cover for systems provided with DSD2 (layout view).

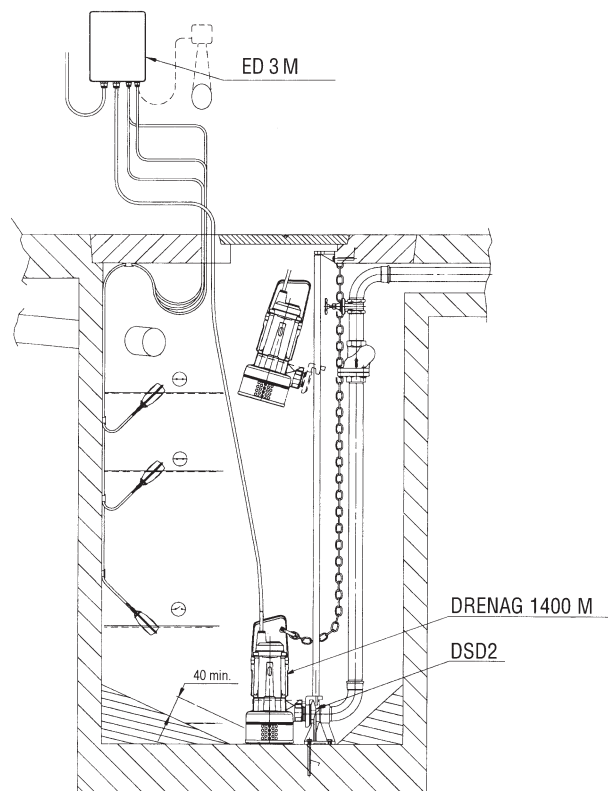

Fixed installation with 1 Drenag 1400 M pump with DSD2 device, complete with ED 3 M control unit, with two minimum and maximum level control floats and one alarm float.

\* Technical data of control units from page 32