FEKABOX 200

FITTED FOR
FEKA 600 MA
FEKA VS 550-750 M-A
FEKA VX 550-750 M-A



GENERAL DATA

Applications

Automatic collection and lifting system, ideal for collecting and pumping black water and domestic/industrial waste from basements located under the level of the drains into sewers.

Pumped liquid

Phreatic water, rain water, clear waste water, black waste water and water from rivers and lakes.

Technical features

Hydraulic part

FEKABOX 200 comprises a high density polyethylene tank with an effective capacity of 200 litres, with a sturdy gas and liquid proof sealed cover, stainless steel base plate and pipe fittings for connecting the pump to the drains. Complete with: special cable holder, DN50 and DN110 suction manifolds and 2" delivery manifolds. Complete with connector for DN50 vent tube. An alarm float can be used on request.

Fitted for operation with one automatic electric pump (see models in graph) **to be ordered separately.**

Supply

The station is supplied on a pallet wrapped in a tough cardboard pack, complete with an installation and maintenance instructions sheet.

A float cable clamp kit is supplied (clamp fastened to the motor jacket, with height adjustment).

TECHNICAL DATA

- Operating range: from 1 to 24 m³/h with head up to 9 metres
- Liquid temperature range: +50°C

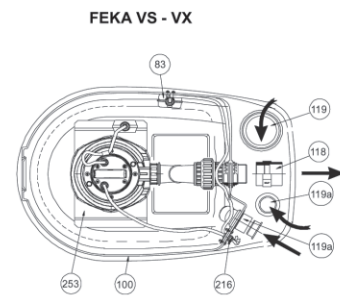
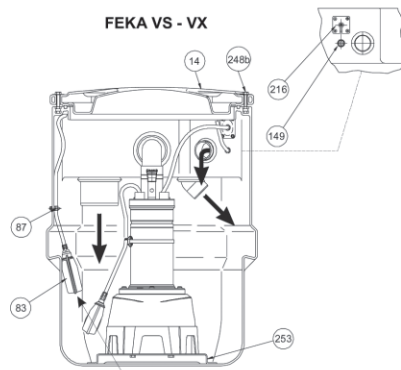
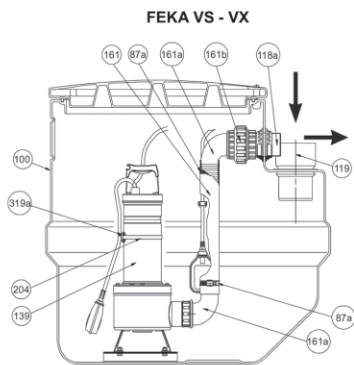

SUPPLIED ONLY ON REQUEST

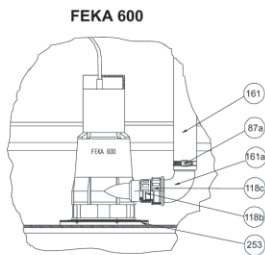
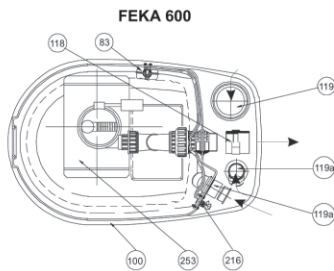

14	TANK COVER
83	"ALARM" FLOAT (not supplied)
87	CABLE CLAMP
87a	TUBE CLAMP Ø57
100	TANK
118	SLEEVE 63X2"
118a	THREADED PIPE 100X2"
118b	ADAPTER M-F 1 1/4" - 1 1/2"
118c	ADAPTER M-F 1 1/2" - 2"
119	UNION DN 110 (inlet)
119a	45° ELBOW DN 50 (inlet - ventilation)
139	PUMP
149	CABLE HOLDER PG 11
161	RUBBER PIPE 57X50 L=300
161a	BENT HOSE ADAPTER 2"X50
161b	UNION 3 pcs WITH O-RING (2")
204	CABLE CLAMP
216	SPECIAL CABLE GLAND
248b	COVER SCREW
253	PUMP POSITIONING PLATE
319a	CLAMP

The performance curves are based on the kinematic viscosity values = 1 mm²/s and density equal to 1000 kg/m³. Curve tolerance according to ISO 9906.

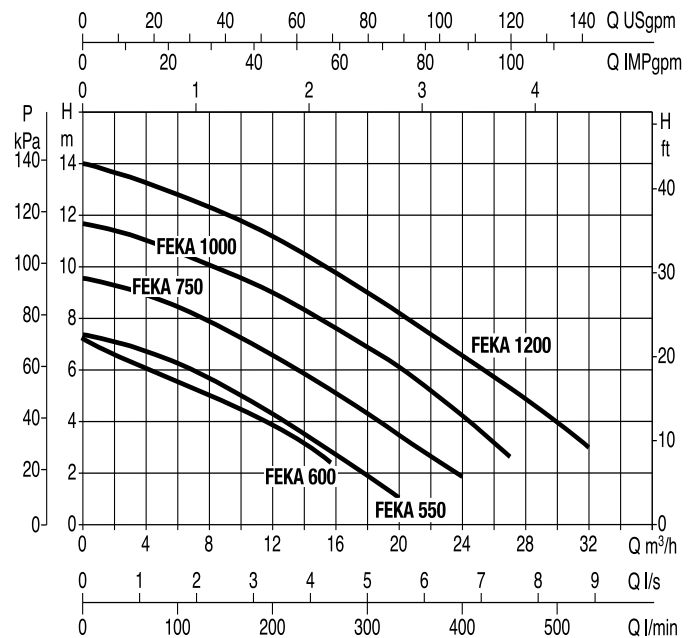
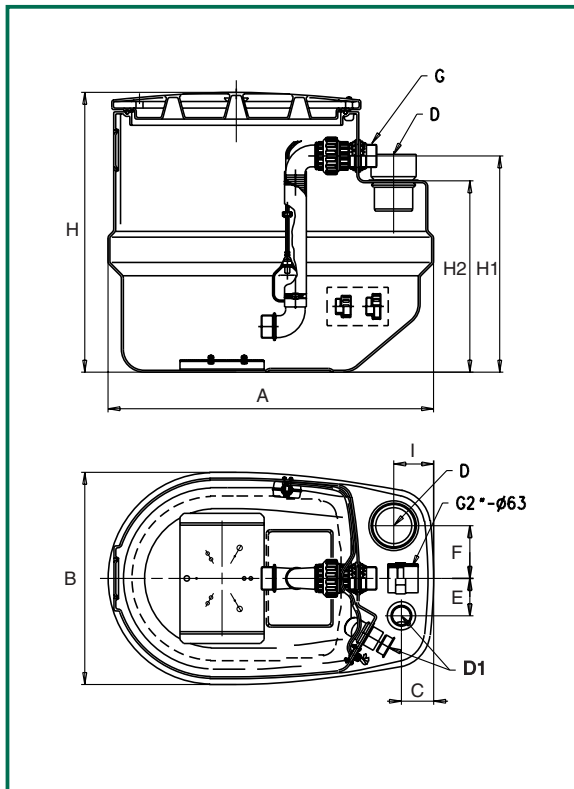

MODEL	A	B	C	D	D1	E	F	G	H	H1	H2	I	WEIGHT Kg
FEKABOX 200	850	555	85	DN 110	DN 50	100	140	2"	735	565	500	105	25