

# FEKAFOS 200

FITTED FOR  
 FEKA 600 NA  
 FEKA VS/VX 550 M-NA/T-NA  
 FEKA VS/VX 750 M-NA/T-NA  
 FEKA VS/VX 1000 M-NA/T-NA  
 FEKA VS/VX 1200 M-NA/T-NA



## GENERAL DATA

### Applications

Automatic system for collecting, lifting and pumping black water and domestic/industrial waste from basements located under the level of the drains into sewers.

### Pumped liquid

Phreatic water, rain water, clear waste water, black waste water and water from rivers and lakes.

### Technical features

FEKABOS 200 comprises a high density polyethylene tank with an effective capacity of 200 litres, with a sturdy gas and liquid proof sealed cover, stainless steel base plate and pipe fittings for connecting the pump to the drains. Complete with 2 bulb floats mounted on a stainless steel support, cable holder for connecting the float and pump cables to the electrical panel (**to order separately according to the table**).

Complete with DN50 and DN110 suction manifolds and 2" delivery manifolds.

Complete with connector for DN50 vent tube.

An alarm float can be used on request.

Fitted for operation with one automatic electric pump (see models in graph) **to be ordered separately**.

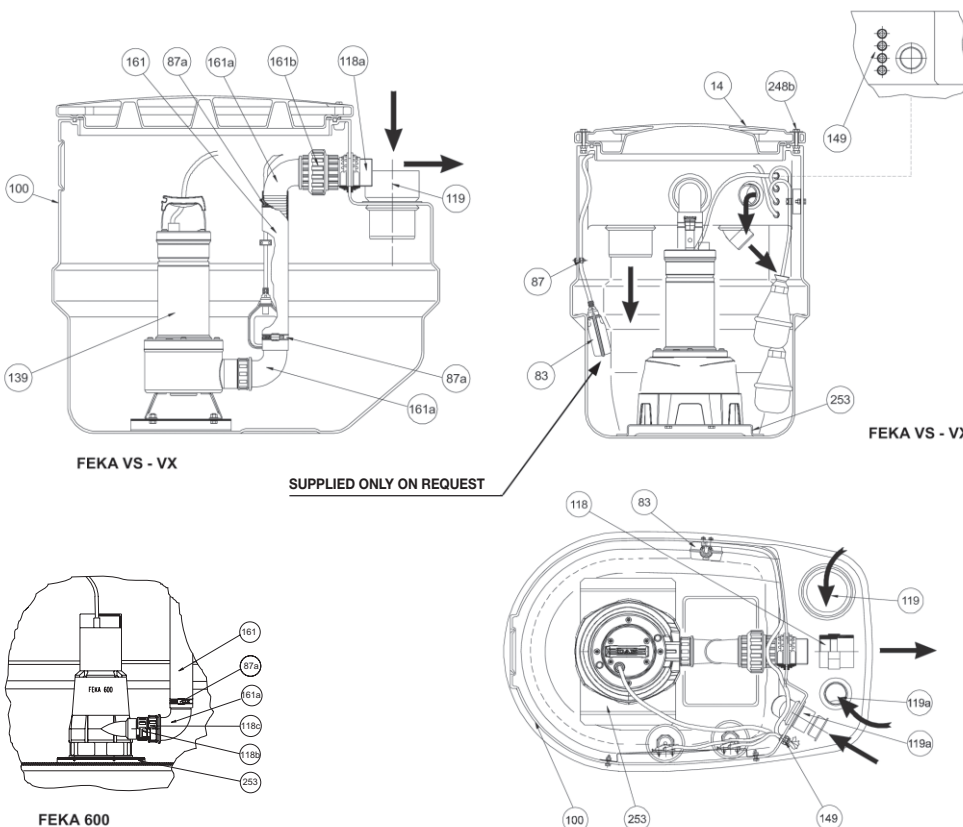

14	TANK COVER
83	"ALARM" FLOAT (not supplied)
87	CABLE CLAMP
87a	TUBE CLAMP Ø57
100	TANK
118	SLEEVE 63X2"
118a	THREADED PIPE 100X2"
118b	ADAPTER M-F 1 1/4" - 1 1/2"
118c	ADAPTER M-F 1 1/2" - 2"
119	UNION DN 110 (inlet)
119a	45° ELBOW DN 50 (inlet - ventilation)
139	PUMP
149	CABLE HOLDER PG 11
161	RUBBER PIPE 57X50 =300
161a	CURVE RUBBER HOLDER 2"X50
161b	UNION 3 Pcs WITH O-RING (2")
248b	COVER SCREW
253	PUMP POSITIONING PLATE

# TECHNICAL DATA

- Operating range: from 1 to 35 m<sup>3</sup>/h with head up to 9 metres
- Liquid temperature range: +50°C

The performance curves are based on the kinematic viscosity values = 1 mm<sup>2</sup>/s and density equal to 1000 kg/m<sup>3</sup>. Curve tolerance according to ISO 9906.

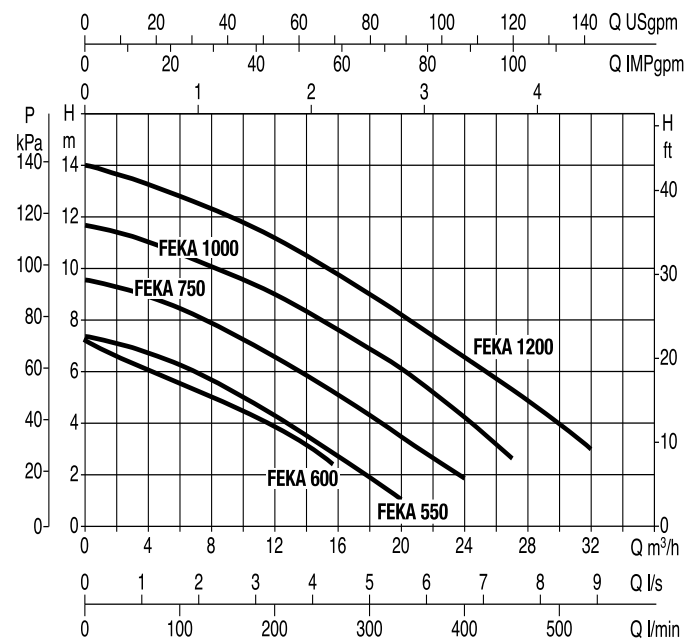
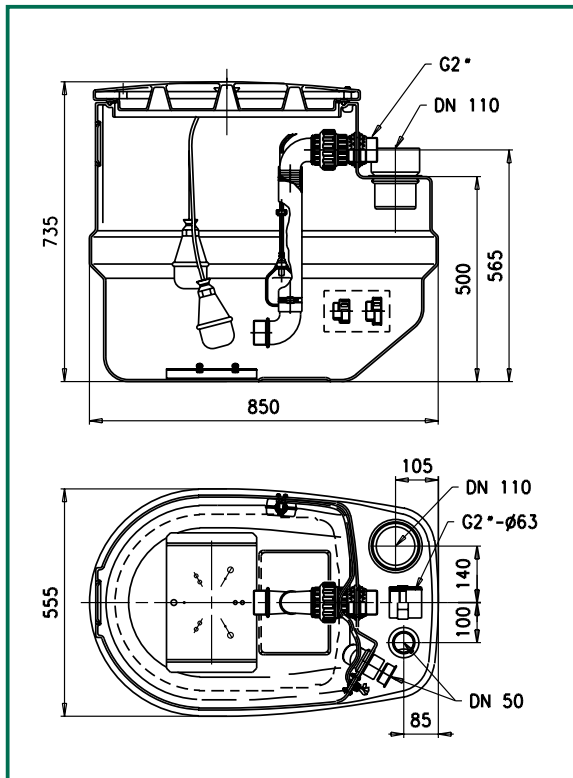

MODEL	A	B	C	D	D1	E	F	G	H	H1	H2	I	WEIGHT Kg
<b>FEKAFOS 200</b>	850	555	85	DN 50	DN 110	100	140	2"	735	500	565	105	28

## CHOICE OF PUMP/ELECTRICAL PANEL

PUMP MODEL	P2 NOMINAL ELECTRIC PUMP		SINGLE-PHASE 230V~50 Hz	THREE-PHASE 400V~50 Hz
	kW	HP		
<b>FEKA 600 NA</b>	0,55	0,75	ED1,3 M	ED1 T
<b>FEKA VS-VX 550 NA</b>	0,55	0,75	ED1,3 M	ED1 T
<b>FEKA VS-VX 750 NA</b>	0,75	1	ED1,3 M	ED1 T
<b>FEKA VS-VX 1000 NA</b>	1	1,36	ED1,3 M	ED1,5 T
<b>FEKA VS-VX 1200 NA</b>	1,2	1,6	ED1,3 M	ED1,5 T