

Single impeller centrifugal pumps manufactured from stainless steel AISI 304, suitable for water supply, treatment & irrigation. Air conditioning systems and general water pumping including moderately aggressive liquids



SPECIFICATIONS

- Maximum working pressure: 8 bar
- Maximum liquid temperature: 35°C according EN 60335-2-41 for domestic uses 60°C for other uses of CD 70/05-70/07-90/10 90°C for other models

MATERIALS

- Pump body, impeller, diffuser, casing cover, bracket, shaft, motor casing and fan cover in AISI 304
- Mechanical seal in carbon/ceramic/NBR
- Special mechanical seal are available on demand

TECHNICAL DATA

- T.E.F.C. 2 poles motor
- Insulation class F
- Protection degree IP55
- 1~230V ± 10% 50Hz, 3~230/400V ± 10% 50Hz
- Permanent split capacitor and automatic thermal overload protection for single-phase version
- Thermal protection to be provided by the user for three-phase version
- DNA 1¹/₂ for CD200, DNA 1¹/₄ for the other models
- DNM 1"

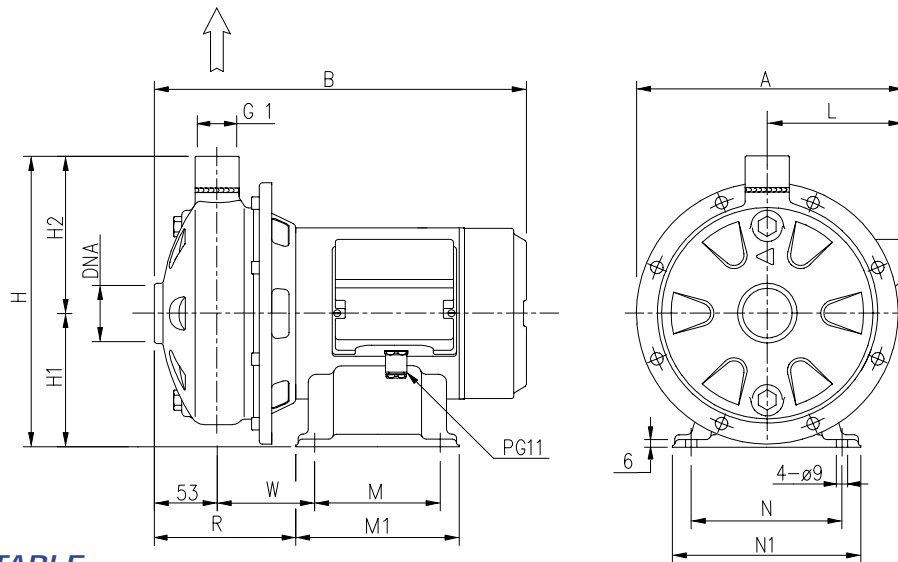

DIMENSIONAL TABLE

Pump type		Dimensions (mm)														Weight kg				
		A		B	H	H1	H2	L		M		M1		N	N1		R	W	DNA	
Single-phase	Three-phase	1-	3-					1-	3-	1-	3-	1-	3-							
CDM 70/05	CD 70/05	210	206	298	229	106	123	102	106	100	100	130	130	120	150	101	63	63	G 1 1/4	9,4
CDM 70/07	CD 70/07	210	206	298	229	106	123	102	106	100	100	130	130	120	150	101	63	63	G 1 1/4	10,8
CDM 70/12	CD 70/12	218	218	328	250	118	132	102	102	100	100	130	130	120	150	131	93	93	G 1 1/4	14,1
CDM 90/10	CD 90/10	210	206	328	229	106	123	102	106	100	100	130	130	120	150	131	93	93	G 1 1/4	12,4
CDM 120/07	CD 120/07	210	206	298	229	106	123	102	106	100	100	130	130	120	150	101	63	63	G 1 1/4	10,7
CDM 120/12	CD 120/12	206	206	328	229	106	123	102	102	100	100	130	130	120	150	101	63	63	G 1 1/4	13,3
CDM 120/20	CD 120/20	226	226	356	250	118	132	110	110	100	100	130	130	120	150	131	93	93	G 1 1/4	17,3
CDM 200/12	CD 200/12	206	206	328	229	106	123	102	102	100	100	130	130	120	150	131	93	93	G 1 1/2	12,7
CDM 200/20	CD 200/20	214	214	356	229	106	123	110	110	120	120	150	150	140	170	133	95	95	G 1 1/2	16,7
	CD 200/25	-	226	366	250	118	132	-	110	-	120	-	150	140	170	138	100	100	G 1 1/2	17,4

PERFORMANCE CHART (according to ISO 9906 Annex A)

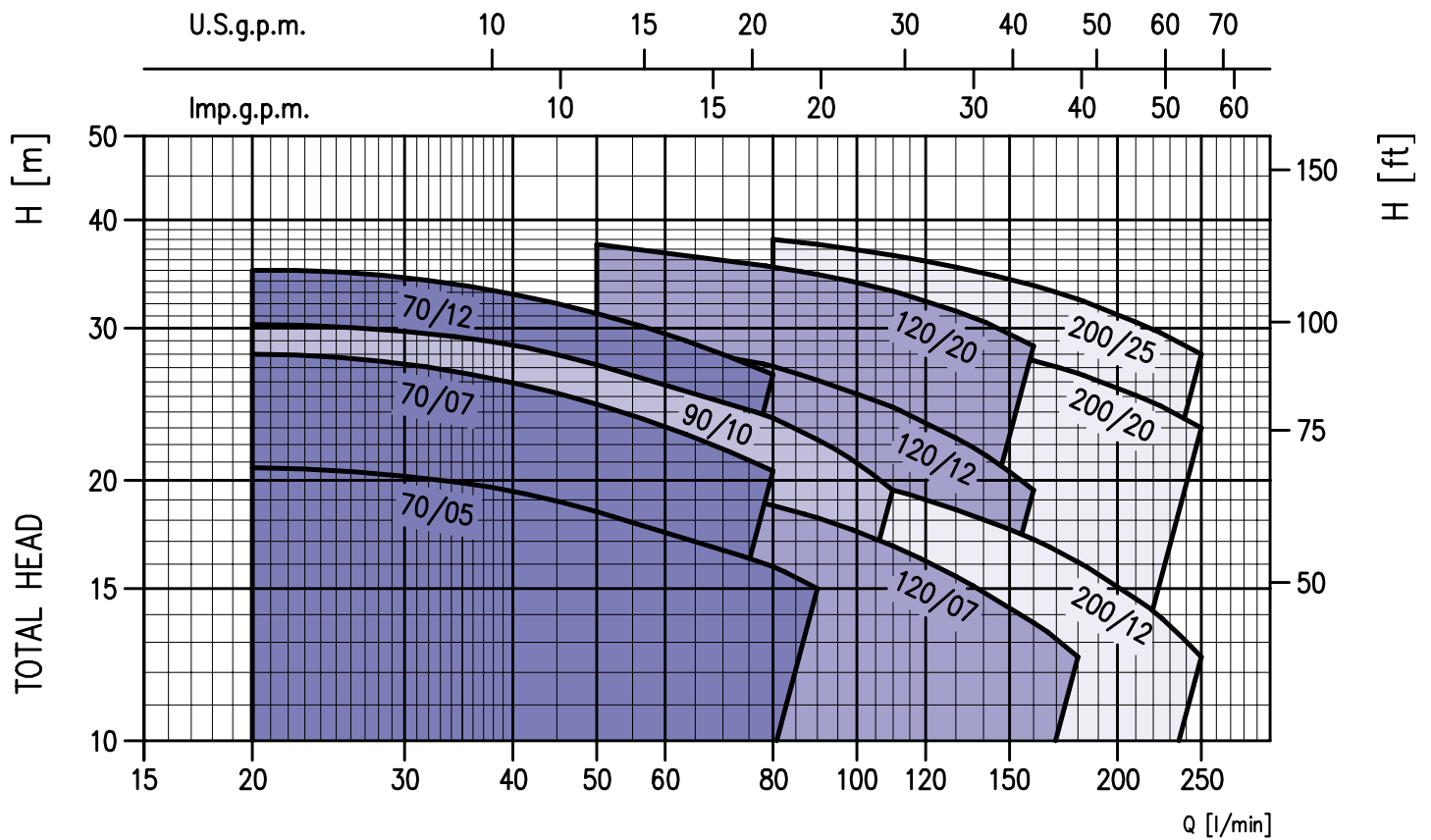

PERFORMANCE TABLE

Pump type		kW	Capacitor		Absorbed Current (A)			l/min m ³ /h	Q=Capacity									
Single-phase 230V 50Hz	Three-phase 230/400V 50Hz		μF	V _c	Single-phase	Three-phase 230V 400V			20	50	80	90	110	130	160	180	210	250
								H=Total head										
CDM 70/05	CD 70/05	0,37	12,5	450	3,1	2,4	1,4	20,7	18,4	15,9	15	-	-	-	-	-	-	
CDM 70/07	CD 70/07	0,55	16	450	4,6	3,5	2,0	28	24,5	20,5	-	-	-	-	-	-	-	
CDM 70/12	CD 70/12	0,9	31,5	450	6,5	5,0	2,9	35	31,2	26,5	-	-	-	-	-	-	-	
CDM 90/10	CD 90/10	0,75	20	450	5,6	4,0	2,3	30,3	27,2	23,6	22,3	19,5	-	-	-	-	-	
CDM 120/07	CD 120/07	0,55	16	450	4,6	3,2	1,85	-	20,5	18,7	18,1	16,8	15,5	13,7	12,5	-	-	
CDM 120/12	CD 120/12	0,9	31,5	450	6,9	4,9	2,8	-	29,5	27,1	26,1	24,3	22,4	19,5	-	-	-	
CDM 120/20	CD 120/20	1,5	40	450	9,7	7,0	4,0	-	37,5	35,3	34,6	33,1	31,4	28,6	-	-	-	
CDM 200/12	CD 200/12	0,9	31,5	450	6,3	4,7	2,7	-	-	20,6	20,2	19,5	18,5	17,1	16,1	14,6	12,5	
CDM 200/20	CD 200/20	1,5	40	450	9,8	7,0	4,0	-	-	31	30,6	29,7	28,9	27,5	26,6	25,1	23	
CDM 200/25	CD 200/25	1,8	-	-	-	8,6	5,0	-	-	-	38	37,5	36,4	35,3	33,6	32,4	30,5	28

PERFORMANCE CURVES CD 70-90 series (according to ISO 9906 Annex A)

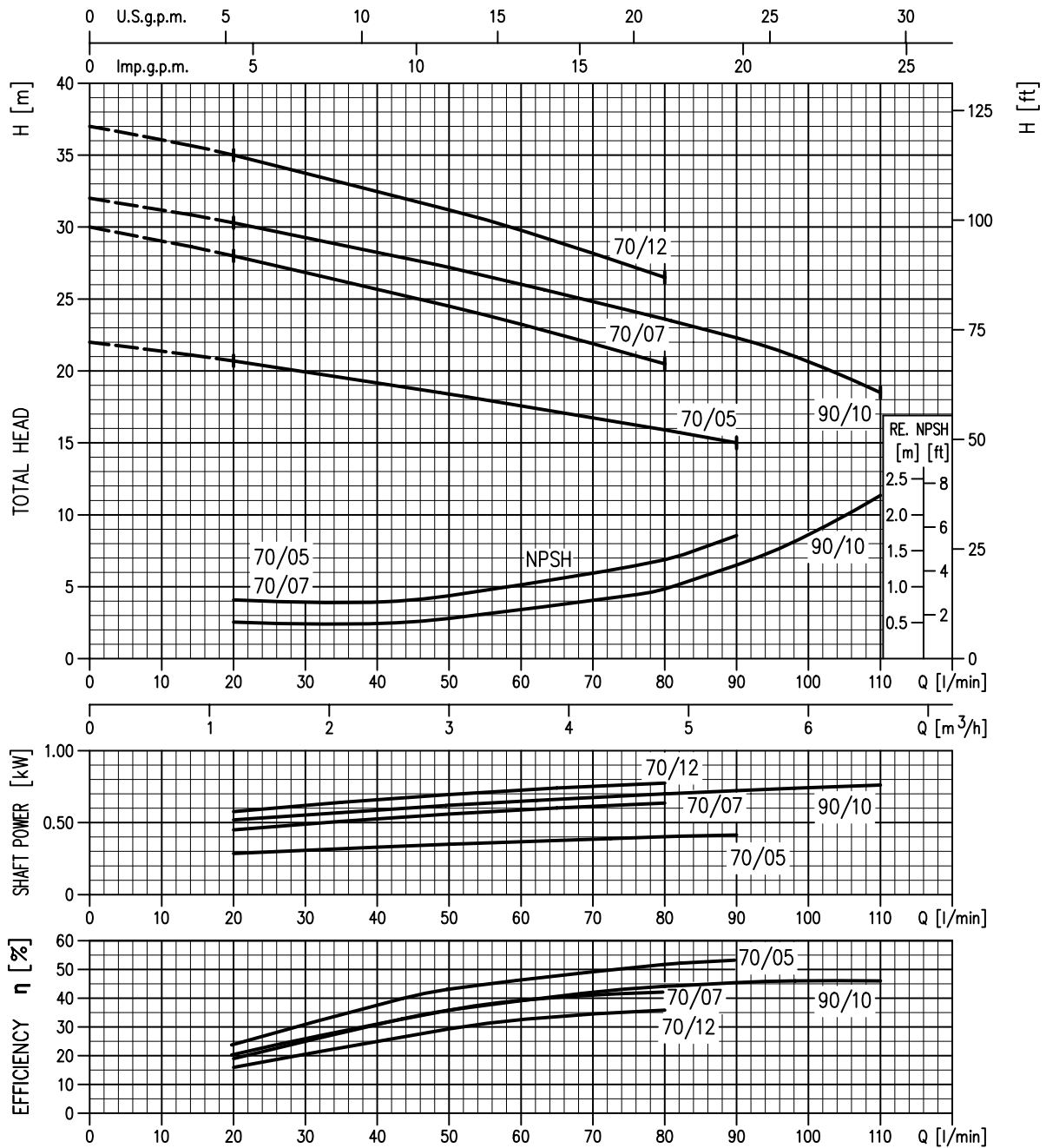

PERFORMANCE CURVES CD 120 series (according to ISO 9906 Annex A)

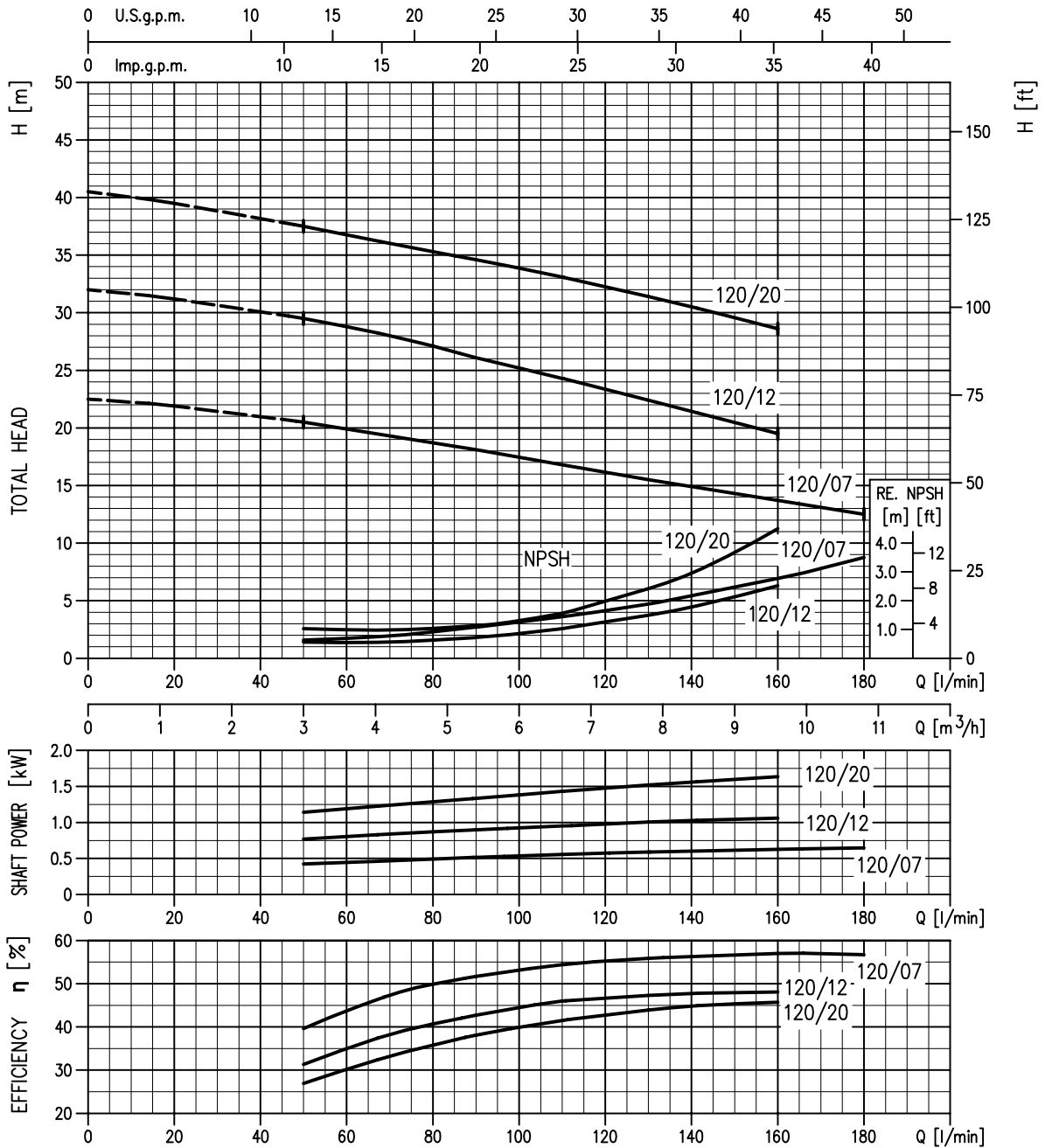

PERFORMANCE CURVES CD 200 series (according to ISO 9906 Annex A)

